

BLACK+ DECKER™

20V MAX*, 40V MAX** CORDLESS CHAIN SAW

INSTRUCTION MANUAL



CATALOG NUMBER
LCS1020 (20V MAX*)

*Maximum initial battery pack voltage (measured without a workload) is 20 volts. The nominal voltage is 18.



CATALOG NUMBER
LCS1240 (40V MAX)**

**Maximum initial battery pack voltage (measured without a workload) is 40 volts. The nominal voltage is 36.

Thank you for choosing BLACK+DECKER!

PLEASE READ BEFORE RETURNING THIS PRODUCT FOR ANY REASON.

If you have a question or experience a problem with your BLACK+DECKER purchase, go to <http://www.blackanddecker.com/Instantanswers>. If you can't find the answer or do not have access to the Internet, call 1-800-544-6986 from 8 a.m. to 5 p.m. EST Mon. - Fri. to speak with an agent. Please have the catalog number available when you call.

SAVE THIS MANUAL FOR FUTURE REFERENCE.

VEA EL ESPAÑOL EN LA CONTRAPORTADA. INSTRUCTIVO DE OPERACIÓN, CENTROS DE SERVICIO Y PÓLIZA DE GARANTÍA. ADVERTENCIA: LÉASE ESTE INSTRUCTIVO ANTES DE USAR EL PRODUCTO.

KEY INFORMATION YOU SHOULD KNOW:

READ INSTRUCTIONS THOROUGHLY BEFORE OPERATING!

- DO NOT OVER-TENSION CHAIN. Refer to "Adjusting Chain Tension" for proper method of tensioning chain.
- Retighten chain frequently during first two hours of use.

To register your new product, visit
www.BlackandDecker.com/NewOwner

SAFETY GUIDELINES - DEFINITIONS

It is important for you to read and understand this manual. The information it contains relates to protecting YOUR SAFETY and PREVENTING PROBLEMS. The symbols below are used to help you recognize this information.

⚠ DANGER: Indicates an imminently hazardous situation which, if not avoided, will result in death or serious injury.

⚠ WARNING: Indicates a potentially hazardous situation which, if not avoided, could result in death or serious injury.

⚠ CAUTION: Indicates a potentially hazardous situation which, if not avoided, may result in minor or moderate injury.

NOTICE: Used without the safety alert symbol indicates potentially hazardous situation which, if not avoided, may result in property damage.

GENERAL POWER TOOL SAFETY WARNINGS

⚠ WARNING: Read all safety warnings and all instructions. Failure to follow the warnings and instructions may result in electric shock, fire and/or serious injury.

SAVE ALL WARNINGS AND INSTRUCTIONS FOR FUTURE REFERENCE

The term "power tool" in the warnings refers to your mains-operated (corded) power tool or battery-operated (cordless) power tool.

1) WORK AREA SAFETY

- a) Keep work area clean and well lit. Cluttered or dark areas invite accidents.
- b) Do not operate power tools in explosive atmospheres, such as in the presence of flammable liquids, gases or dust. Power tools create sparks which may ignite the dust or fumes.
- c) Keep children and bystanders away while operating a power tool. Distractions can cause you to lose control.

2) ELECTRICAL SAFETY

- a) Power tool plugs must match the outlet. Never modify the plug in any way. Do not use any adapter plugs with earthed (grounded) power tools. Unmodified plugs and matching outlets will reduce risk of electric shock.
- b) Avoid body contact with earthed or grounded surfaces such as pipes, radiators, ranges and refrigerators. There is an increased risk of electric shock if your body is earthed or grounded.
- c) Do not expose power tools to rain or wet conditions. Water entering a power tool will increase the risk of electric shock.
- d) Do not abuse the cord. Never use the cord for carrying, pulling or unplugging the power tool. Keep cord away from heat, oil, sharp edges or moving parts. Damaged or

entangled cords increase the risk of electric shock.

- e) When operating a power tool outdoors, use an extension cord suitable for outdoor use. Use of a cord suitable for outdoor use reduces the risk of electric shock.
 - f) If operating a power tool in a damp location is unavoidable, use a ground fault circuit interrupter (GFCI) protected supply. Use of a GFCI reduces the risk of electric shock.
- #### 3) PERSONAL SAFETY
- a) Stay alert, watch what you are doing and use common sense when operating a power tool. Do not use a power tool while you are tired or under the influence of drugs, alcohol or medication. A moment of inattention while operating power tools may result in serious personal injury.
 - b) Use personal protective equipment. Always wear eye protection. Protective equipment such as dust mask, nonskid safety shoes, hard hat, or hearing protection used for appropriate conditions will reduce personal injuries.
 - c) Prevent unintentional starting. Ensure the switch is in the off position before connecting to power source and/ or battery pack, picking up or carrying the tool. Carrying power tools with your finger on the switch or energizing power tools that have the switch on invites accidents.
 - d) Remove any adjusting key or wrench before turning the power tool on. A wrench or a key left attached to a rotating part of the power tool may result in personal injury.
 - e) Do not overreach. Keep proper footing and balance at all times. This enables better control of the power tool in unexpected situations.
 - f) Dress properly. Do not wear loose clothing or jewelry. Keep your hair, clothing and gloves away from

moving parts. Loose clothes, jewelry or long hair can be caught in moving parts.

- g) If devices are provided for the connection of dust extraction and collection facilities, ensure these are connected and properly used.

Use of dust collection can reduce dust-related hazards.

4) POWER TOOL USE AND CARE

- a) Do not force the power tool. Use the correct power tool for your application. *The correct power tool will do the job better and safer at the rate for which it was designed.*

- b) Do not use the power tool if the switch does not turn it on and off. *Any power tool that cannot be controlled with the switch is dangerous and must be repaired.*

- c) Disconnect the plug from the power source and/or the battery pack from the power tool before making any adjustments, changing accessories, or storing power tools. *Such preventive safety measures reduce the risk of starting the power tool accidentally.*

- d) Store idle power tools out of the reach of children and do not allow persons unfamiliar with the power tool or these Instructions to operate the power tool. *Power tools are dangerous in the hands of untrained users.*

- e) Maintain power tools. Check for misalignment or binding of moving parts, breakage of parts and any other condition that may affect the power tool's operation. If damaged, have the power tool repaired before use. *Many accidents are caused by poorly maintained power tools.*

- f) Keep cutting tools sharp and clean. *Properly maintained cutting tools with sharp cutting edges are less likely to bind and are easier to control.*

- g) Use the power tool, accessories and tool bits, etc. in accordance with these Instructions, taking into account the working conditions and the work to be performed. *Use of the power tool for operations different from those intended could result in a hazardous situation.*

5) BATTERY TOOL USE AND CARE

- a) Recharge only with the charger specified by the manufacturer. A charger that is suitable for one type of battery pack may create a risk of fire when used with another battery pack.

- b) Use power tools only with specifically designated battery packs. Use of any other battery packs may create a risk of injury and fire.

- c) When battery pack is not in use, keep it away from other metal objects like paper clips, coins,

keys, nails, screws, or other small metal objects that can make a connection from one terminal to another. Shorting the battery terminals together may cause burns or a fire.

- d) Under abusive conditions, liquid may be ejected from the battery, avoid contact. If contact accidentally occurs, flush with water. If liquid contacts eyes, additionally seek medical help. Liquid ejected from the battery may cause irritation or burns.

6) SERVICE

- a) Have your power tool serviced by a qualified repair person using only identical replacement parts. *This will ensure at the safety of the power tool is maintained.*

READ ALL INSTRUCTIONS

CHAIN SAW SAFETY

WARNINGS:

- Keep all parts of the body away from the saw chain when the chain saw is operating. Before you start the chain saw, make sure the saw chain is not contacting anything. *A moment of inattention while operating chain saws may cause entanglement of your clothing or body with the saw chain.*
- Always hold the chain saw with your right hand on the rear handle and your left hand on the front handle. *Holding the chain saw with a reversed hand configuration increases the risk of personal injury and should never be done.*
- Hold the power tool by insulated gripping surfaces only, because the saw chain may contact hidden wiring. *Saw chains contacting a "live" wire may make exposed metal parts of the power tool "live" and could give the operator an electric shock.*
- Wear safety glasses and hearing protection. Further protective equipment for head, hands, legs and feet is recommended. *Adequate protective clothing will reduce personal injury by flying debris or accidental contact with the saw chain.*
- Do not operate a chain saw in a tree. *Operation of a chain saw while up in a tree may result in personal injury.*
- Always keep proper footing and operate the chain saw only when standing on fixed, secure and level surface. *Slippery or unstable surfaces such as ladders may cause a loss of balance or control of the chain saw.*
- When cutting a limb that is under tension be alert for spring back. *When the tension in the wood fibers is released the spring loaded limb may strike the operator and/or throw the chain saw out*

of control.

- **Use extreme caution when cutting brush and saplings.** *The slender material may catch the saw chain and be whipped toward you or pull you off balance.*
- **Carry the chain saw by the front handle with the chain saw switched off and away from your body.** *When transporting or storing the chain saw always fit the scabbard. Proper handling of the chain saw will reduce the likelihood of accidental contact with the moving saw chain.*
- **Follow instructions for lubricating, chain tensioning and changing accessories.** *Improperly tensioned or lubricated chain may either break or increase the chance for kickback.*
- **Keep handles dry, clean, and free from oil and grease.** *Greasy, oily handles are slippery causing loss of control.*
- **Cut wood only. Do not use chain saw for purposes not intended.** *For example: do not use chain saw for cutting plastic, masonry or non-wood building materials. Use of the chain saw for operations different than intended could result in a hazardous situation.*

CAUSES AND OPERATOR PREVENTION OF KICKBACK:

Kickback may occur when the nose or tip of the guide bar touches an object, or when the wood closes in and pinches the saw chain in the cut.

Tip contact in some cases may cause a sudden reverse reaction, kicking the guide bar up and back towards the operator.

Pinching the saw chain along the top of the guide bar may push the guide bar rapidly back towards the operator.

Either of these reactions may cause you to lose control of the saw which could result in serious personal injury. Do not rely exclusively upon the safety devices built into your saw. As a chain saw user, you should take several steps to keep your cutting jobs free from accident or injury. Kickback is the result of tool misuse and/or incorrect operating procedures or conditions and can be avoided by taking proper precautions as given below:

- **Maintain a firm grip, with thumbs and fingers encircling the chain saw handles, with both hands on the saw and position your body and arm to allow you to resist kickback forces.** *Kickback forces can be controlled by the operator, if proper precautions are taken. Do not let go of the chain saw.*
- **Do not overreach and do not cut above chest height.** *This helps prevent unintended tip contact and enables better control of the chain saw in unexpected situations.*
- **Only use replacement bars and chains**

specified by the manufacturer. *Incorrect replacement bars and chains may cause chain breakage and/or kickback.*

- **Follow the manufacturer's sharpening and maintenance instructions for the saw chain.** *Decreasing the depth gauge height can lead to increased kickback.*

THE FOLLOWING PRECAUTIONS SHOULD BE FOLLOWED TO MINIMIZE KICKBACK:

(1.) **Grip Saw Firmly.** Hold the chain saw firmly with both hands when the motor is running.

Use a firm grip with thumbs and fingers encircling the chain saw handles. Chain saw will pull forward when cutting on the bottom edge of the bar, and push backward when cutting along the top edge of the bar.

(2.) Do not over reach.

(3.) Keep proper footing and balance at all times.

(4.) Don't let the nose of the guide bar contact a log, branch, ground or other obstruction.

(5.) Don't cut above shoulder height.

(6.) Use devices such as low kickback chain and reduced kickback guide bars that reduce the risks associated with kickback.

(7.) Only use replacement bars and chains specified by the manufacturer or the equivalent.

(8.) Never let the moving chain contact any object at the tip of the guide bar.

(9.) Keep the working area free from obstructions such as other trees, branches, rocks, fences, stumps, etc. Eliminate or avoid any obstruction that your saw chain could hit while you are cutting through a particular log or branch.

(10.) Keep your saw chain sharp and properly tensioned. A loose or dull chain can increase the chance of kickback.

Check tension at regular intervals with the motor stopped and tool unplugged, never with the motor running.

(11.) Begin and continue cutting only with the chain moving at full speed. If the chain is moving at a slower speed, there is a greater chance for kickback to occur.

(12.) Cut one log at a time.

(13.) Use extreme caution when re-entering a previous cut. Engage ribbed bumpers into wood and allow chain to reach full speed before proceeding with cut.

(14.) Do not attempt plunge cuts or bore cuts.

(15.) Watch for shifting logs or other forces that could close a cut and pinch or fall into chain.

KICKBACK SAFETY FEATURES

⚠ WARNING: The following features are included on your saw to help reduce the hazard of kickback; however such features will not totally eliminate this dangerous reaction. As a chain saw user do not rely only on safety devices. You must follow all safety precautions, instructions, and

maintenance in this manual to help avoid kickback and other forces which can result in serious injury.

- **Reduced-Kickback Guide Bar**, designed with a small radius tip which reduces the size of the kickback danger zone on bar tip. A reduced - kickback guide bar is one which has been demonstrated to significantly reduce the number and seriousness of kickbacks when tested in accordance with safety requirements for electric chain saws.
- **Low-Kickback Chain**, designed with a contoured depth gauge and guard link which deflect kickback force and allow wood to gradually ride into the cutter. A low-kickback chain is a chain which has met kickback performance requirements of ANSI B175.1-2012.
- **Do not operate chain saw while in a tree, on a ladder, on a scaffold, or from any unstable surface.**
- **Hold tool by insulated gripping surfaces when performing an operation where the cutting tool may contact hidden wiring.** Contact with a "live" wire will make exposed metal parts of the tool "live" and shock the operator.
- **Do not attempt operations beyond your capacity or experience.** Read thoroughly and understand completely all instructions in this manual.
- **Before you start chain saw, make sure saw chain is not contacting any object.**
- **Do not operate a chain saw with one hand! Serious Injury to the operator, helpers, or bystanders may result from one handed operation.** A chain saw is intended for two-handed use only.
- **Keep the handles dry, clean, and free of oil or grease.**
- **Do not allow dirt, debris, or sawdust to build up on the motor or outside air vents.**
- **Stop the chain saw before setting it down.**
- **Do not cut vines and/or small under brush.**
- **Use extreme caution when cutting small size brush and saplings** because slender material may catch the saw chain and be whipped toward you or pull you off balance.

⚠ WARNING: Some dust created by power sanding, sawing, grinding, drilling, and other construction activities contains chemicals known to the State of California to cause cancer, birth defects or other reproductive harm. Some examples of these chemicals are:

- lead from lead-based paints,
- crystalline silica from bricks and cement and other masonry products, and
- arsenic and chromium from chemically-treated lumber.

Your risk from these exposures varies, depending on how often you do this type of work. To reduce your exposure to these chemicals: work in a well ventilated area, and work with approved safety equipment,

such as those dust masks that are specially designed to filter out microscopic particles.

- **Avoid prolonged contact with dust from power sanding, sawing, grinding, drilling, and other construction activities. Wear protective clothing and wash exposed areas with soap and water.** Allowing dust to get into your mouth, eyes, or lay on the skin may promote absorption of harmful chemicals.

⚠ WARNING: Use of this tool can generate and/or disburse dust, which may cause serious and permanent respiratory or other injury. Always use NIOSH/OSHA approved respiratory protection appropriate for the dust exposure. Direct particles away from face and body.

CHAIN SAW NAMES AND TERMS

- **Bucking** - The process of cross cutting a felled tree or log into lengths.
- **Motor Brake** - A device used to stop the saw chain when the trigger is released.
- **Chain Saw Powerhead** - A chain saw without the saw chain and guide bar.
- **Drive Sprocket or Sprocket** - The toothed part that drives the saw chain.
- **Felling** - The process of cutting down a tree.
- **Felling Back Cut** - The final cut in a tree felling operation made on the opposite side of the tree from the notching cut.
- **Front Handle** - The support handle located at or toward the front of the chain saw.
- **Front Hand Guard** - A structural barrier between the front handle of a chain saw and the guide bar, typically located close to the hand position on the front handle.
- **Guide Bar** - A solid railed structure that supports and guides the saw chain.
- **Guide Bar Scabbard** - Enclosure fitted over guide bar to prevent tooth contact when saw is not in use.
- **Kickback** - The backward or upward motion, or both of the guide bar occurring when the saw chain near the nose of the top area of the guide bar contacts any object such as a log or branch, or when the wood closes in and pinches the saw chain in the cut.
- **Kickback, Pinch** - The rapid pushback of the saw which can occur when the wood closes in and pinches the moving saw chain in the cut along the top of the guide bar.
- **Kickback, Rotational** - The rapid upward and backward motion of the saw which can occur when the moving saw chain near the upper portion of the tip of the guide bar contacts an object, such as a log or branch.
- **Limbing** - Removing the branches from a fallen tree
- **Low-Kickback Chain** - A chain that complies with the kickback performance requirements of ANSI B175.1-2012 (when tested on a representative sample of chain saws.)

- **Normal Cutting Position** - Those positions assumed in performing the bucking and felling cuts.
- **Notching Undercut** - A notch cut in a tree that directs the tree's fall.
- **Rear Handle** - The support handle located at or toward the rear of the saw.
- **Reduced Kickback Guide Bar** - A guide bar which has been demonstrated to reduce kickback significantly.
- **Replacement Saw Chain** - A chain that complies with kickback performance requirements of ANSI B175.1-2000 when tested with specific chain saws. It may not meet the ANSI performance requirements when used with other saws.
- **Saw Chain** - A loop of chain having cutting teeth, that cut the wood, and that is driven by the motor and is supported by the guide bar.
- **Ribbed Bumper** - The ribs used when felling or bucking to pivot the saw and maintain position while sawing.
- **Switch** - A device that when operated will complete or interrupt an electrical power circuit to the motor of the chain saw.
- **Switch Linkage** - The mechanism that transmits motion from a trigger to the switch.
- **Switch Lockout** - A movable stop that prevents the unintentional operation of the switch until manually actuated.

INTENDED USE

Your BLACK+DECKER Chain Saw is ideal for pruning applications and cutting small logs up to 10 inches (254 mm) for the LCS1020 and up to 12 inches (305 mm) for the LCS1240 in diameter. This tool is intended for consumer use only.

SAVE THESE INSTRUCTIONS

SYMBOLS

The label on your tool may include the following symbols. The symbols and their definitions are as follows:

- V.....volts
- A.....amperes
- Hz.....hertz
- W.....watts
- min.....minutes
- ~ or AC.....alternating current
- or DC.....direct current
- n_0no load speed
- Ⓛ.....Class I Construction (grounded)
- Ⓧ.....earthing terminal
- ⚠.....safety alert symbol
- Ⓛ.....Class II Construction (double insulated)
- .../min or rpm...revolutions or reciprocation per minute
- m/s.....meters per second
- in.....inches
- mm.....millimeters
- 📖.....Read instruction manual before use

- 👤.....Use proper respiratory protection
- 👁.....Use proper eye protection
- 👂.....Use proper hearing protection
- ↻.....Rotational direction of the saw chain
- 🚫.....Contact of the guide bar tip with any object should be avoided
- 🚫.....Tip contact can cause the guide bar to move suddenly upward and backward, which can cause serious injury
- 👉👉.....Always use two hands when operating the chain saw

IMPORTANT SAFETY INSTRUCTIONS FOR BATTERY CHARGERS

SAVE THESE INSTRUCTIONS: THIS MANUAL CONTAINS IMPORTANT SAFETY INSTRUCTIONS FOR BATTERY CHARGERS.

- Before using charger, read all instructions and cautionary markings on charger, battery pack, and product using battery pack.

⚠ **WARNING: SHOCK HAZARD.** Do not allow any liquid to get inside charger.

⚠ **WARNING: BURN HAZARD.** To reduce the risk of injury, charge only designated **BLACK+DECKER** batteries. Other types of batteries may burst causing personal injury and damage.

⚠ **CAUTION:** Under certain conditions, with the charger plugged in to the power supply, the charger can be shorted by foreign material. Foreign materials of a conductive nature such as, but not limited to, steel wool, aluminum foil, or any buildup of metallic particles should be kept away from charger cavities. Always unplug the charger from the power supply when there is no battery pack in the cavity. Unplug charger before attempting to clean.

⚠ **WARNING:** The charger supplied with this product is intended to be plugged in such that it is correctly orientated in a vertical or floor mount position.

- **DO NOT attempt to charge the battery pack with any chargers other than the ones in this manual.** The charger and battery pack are specifically designed to work together.
- **These chargers are not intended for any uses other than charging designated Black+Decker rechargeable batteries.** Any other uses may result in risk of fire, electric shock or electrocution.
- **Do not expose charger to rain or snow.**
- **Pull by plug rather than cord when disconnecting charger.** This will reduce risk of damage to electric plug and cord.

- **Make sure that cord is located so that it will not be stepped on, tripped over, or otherwise subjected to damage or stress.**
- **Do not use an extension cord unless it is absolutely necessary.** Use of improper extension cord could result in risk of fire, electric shock, or electrocution.
- **An extension cord must have adequate wire size (AWG or American Wire Gauge) for safety.** The smaller the gauge number of the wire, the greater the capacity of the cable, that is 16 gauge has more capacity than 18 gauge. When using more than one extension to make up the total length, be sure each individual extension contains at least the minimum wire size.

Recommended Minimum Wire Size for Extension Cords

Volts	Minimum Gauge for Cord Sets				
	Total Length of Cord in Feet				
120V	0-25	26-50	51-100	101-150	
240V	0-50	51-100	101-200	201-300	
Ampere Rating					
More Than		Not more Than		American Wire Gauge	
0	- 6	18	16	16	14
6	- 10	18	16	14	12
10	- 12	16	16	14	12
12	- 16	14	12	Not Recommended	

- **Do not place any object on top of charger or place the charger on a soft surface that might block the ventilation slots and result in excessive internal heat. Place the charger in a position away from any heat source.** The charger is ventilated through slots in the top and the bottom of the housing.
- **Do not mount charger on wall or permanently affix charger to any surface.** The charger is intended to use on a flat, stable surface (i.e., table top, bench top).
- **Do not operate charger with damaged cord or plug — have them replaced immediately.**
- **Do not operate charger if it has received a sharp blow, been dropped, or otherwise damaged in any way.** Take it to an authorized service center.
- **Do not disassemble charger;** take it to an authorized service center when service or repair is required. Incorrect reassembly may result in a risk of electric shock, electrocution or fire.
- **Disconnect the charger from the outlet before attempting any cleaning.** This will reduce the risk of electric shock. Removing the battery pack will not reduce this risk.
- **NEVER attempt to connect 2 chargers together.**
- **The charger is designed to operate on**

standard household electrical power (120 Volts). Do not attempt to use it on any other voltage.

SAVE THESE INSTRUCTIONS
IMPORTANT SAFETY WARNINGS FOR BATTERY PACKS

⚠ WARNING: For safe operation, read this manual and manuals originally supplied with tool before using the charger.

The battery pack is not fully charged out of the carton. Before using the battery pack and charger, read the safety instructions below. Then follow charging procedures outlined.

READ ALL INSTRUCTIONS

- **Do not incinerate the battery pack even if it is severely damaged or is completely worn out.** The battery pack can explode in a fire. Toxic fumes and materials are created when battery packs are burned.
- **Do not charge or use battery in explosive atmospheres, such as in the presence of flammable liquids, gases or dust.** Inserting or removing the battery from the charger may ignite the dust or fumes.
- **If battery contents come into contact with the skin, immediately wash area with mild soap and water.** If battery liquid gets into the eye, rinse water over the open eye for 15 minutes or until irritation ceases. If medical attention is needed, the battery electrolyte for Li-ion batteries is composed of a mixture of liquid organic carbonates and lithium salts.
- **Contents of opened battery cells may cause respiratory irritation.** Provide fresh air. If symptoms persist, seek medical attention.

⚠ WARNING: BURN HAZARD. BATTERY LIQUID MAY BE FLAMMABLE IF EXPOSED TO SPARK OR FLAME.

- Charge the battery packs only in **Black+ Decker** chargers.
- **DO NOT splash or immerse in water or other liquids.** This may cause premature cell failure.
- **Do not store or use the tool and battery pack in locations where the temperature may reach or exceed 105°F (40°C) (such as outside sheds or metal buildings in summer).**

⚠ WARNING: Never attempt to open the battery pack for any reason. If battery pack case is cracked or damaged, do not insert into charger. Do not crush, drop or damage battery pack. Do not use a battery pack or charger that has received a sharp blow, been dropped, run

over or damaged in any way (i.e., pierced with a nail, hit with a hammer, stepped on). Damaged battery packs should be returned to service center for recycling.

⚠ WARNING: Fire hazard. Do not store or carry battery so that metal objects can contact exposed battery terminals. For example, do not place battery in aprons, pockets, tool boxes, product kit boxes, drawers, etc., with loose nails, screws, keys, etc. **Transporting batteries can possibly cause fires if the battery terminals inadvertently come in contact with conductive materials such as keys, coins, hand tools and the like.** The US Department of Transportation Hazardous Material Regulations (HMR) actually prohibit transporting batteries in commerce or on airplanes (i.e., packed in suitcases and carry-on luggage) **UNLESS** they are properly protected from short circuits. So when transporting individual batteries, make sure that the battery terminals are protected and well insulated from materials that could contact them and cause a short circuit. **NOTE: LI-ION batteries should not be put in checked baggage.**

STORAGE RECOMMENDATIONS

1. The best storage place is one that is cool and dry away from direct sunlight and excess heat or cold.
2. Long-term storage will not harm the battery pack or charger, unless the battery is depleted.

CHARGING PROCEDURE

The standard charger provided will charge a fully depleted battery in about 4-5 hours.

1. Plug the charger into an appropriate outlet before inserting the battery pack.
2. Insert the battery pack into the charger.
3. The green LED will flash indicating that the battery is being charged.
4. The completion of charge is indicated by the green LED remaining on continuously. The pack is fully charged and may be used at this time or left on the charger.

Recharge discharged batteries as soon as possible after use or battery life may be greatly diminished. It is recommended that the batteries be recharged after each use.

IMPORTANT CHARGING NOTES

1. Longest life and best performance can be obtained if the battery pack is charged when the air temperature is between 60°F and 80°F (16°- 27°C). **DO NOT** charge the battery pack in an air temperature below +40°F (+4.5°C), or above +105°F (+40.5°C). This is important and will prevent serious damage to the battery pack.

2. The charger and battery pack may become warm to touch while charging. This is a normal condition, and does not indicate a problem. To facilitate the cooling of the battery pack after use, avoid placing the charger or battery pack in a warm environment such as in a metal shed, or an uninsulated trailer.

3. If the battery pack does not charge properly:

- a. Check current at receptacle by plugging in a lamp or other appliance
- b. Check to see if receptacle is connected to a light switch which turns power off when you turn out the lights.
- c. Move charger and battery pack to a location where the surrounding air temperature is approximately 60°F and 80°F (16°- 27°C)
- d. If charging problems persist, take the tool, battery pack and charger to your local service center.

4. The battery pack should be recharged when it fails to produce sufficient power on jobs which were easily done previously. **DO NOT CONTINUE** to use under these conditions. Follow the charging procedure. You may also charge a partially used pack whenever you desire with no adverse affect on the battery pack.

5. Foreign materials of a conductive nature such as, but not limited to, steel wool, aluminum foil, or any buildup of metallic particles should be kept away from charger cavities. Always unplug the charger from the power supply when there is no battery pack in the cavity. Unplug charger before attempting to clean.

6. Do not freeze or immerse charger in water or any other liquid.

⚠ WARNING: SHOCK HAZARD. Do not allow any liquid to get inside charger. **Never attempt to open the battery pack for any reason. If the plastic housing of the battery pack breaks or cracks, return to a service center for recycling.**

FUNCTIONAL DESCRIPTION

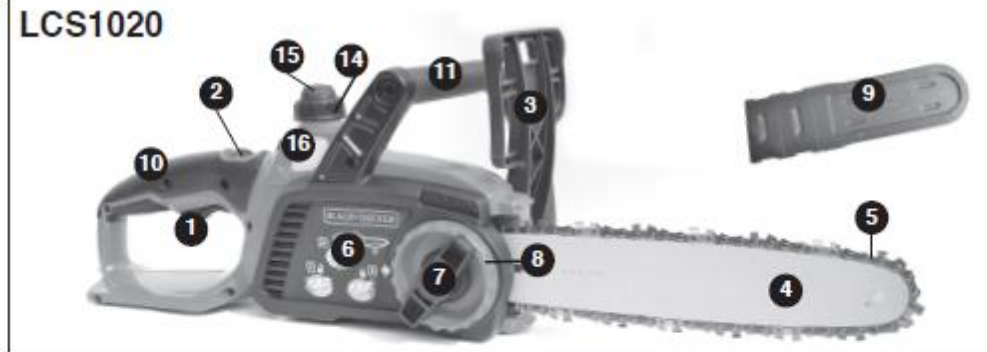

- | | |
|----------------------------|-----------------------------|
| 1. Trigger switch | 9. Guide bar scabbard |
| 2. Lock-off button | 10. Rear handle |
| 3. Front hand guard | 11. Front handle |
| 4. Guide bar | 12. 20V Battery (not shown) |
| 5. Saw chain | 13. 40V Battery (not shown) |
| 6. Sprocket cover | 14. Oil cap |
| 7. Bar adjust locking knob | 15. Oil primer bulb |
| 8. Chain tensioning knob | 16. Oil level indicator |

INSTALLING / REMOVING BATTERY PACK

⚠ WARNING: Make certain the lock-off button is engaged to prevent switch actuation before removing or installing battery.

TO INSTALL BATTERY PACK: Insert battery pack into tool until an audible click is heard, as shown in **Figure A**. Ensure battery pack is fully seated and fully latched into position.

TO REMOVE BATTERY PACK: Depress the battery release button in the back of the battery pack and pull battery pack out of tool (**figure A**).



PREPARING YOUR CHAIN SAW FOR USE

⚠ WARNING: Read and understand all instructions. Failure to follow all instructions listed below may result in electric shock, fire and/or serious personal injury.

ASSEMBLY

INSTALLING THE GUIDE BAR AND SAW CHAIN

⚠ CAUTION: Sharp chain. Always wear protective gloves when handling the chain. The chain is sharp and can cut you when it is not running.

⚠ WARNING: Sharp moving chain. To prevent accidental operation, ensure that battery is removed from the tool before performing the following operations. Failure to do this could result in serious personal injury.

The saw chain (5) and guide bar (4) are packed separately in the carton. The chain has to be attached to the bar, and both must be attached to the body of the tool.

- Place the saw on a firm surface.
- Rotate the bar adjust locking knob (7) counterclockwise as shown in **Figure B** to remove sprocket cover (6).



- Wearing protective gloves, grasp the saw chain (5) and wrap it around the guide bar (4), ensuring the teeth are facing the correct direction (see **figure F**)
- Ensure the chain is properly set in the slot around the entire guide bar.
- Place the saw chain around the sprocket (17) while lining up the slot on the guide bar with the bolt (18) in the base of the tool as shown in **Figure C**.

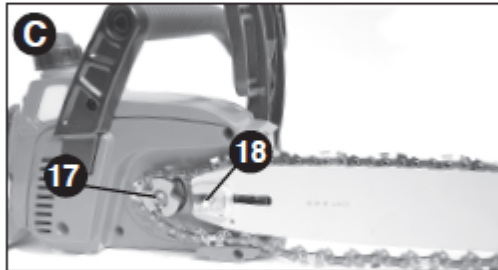

- The tensioning knob must be rotated counterclockwise to its stop. Arrows on the sprocket cover and tensioning knob must align before the cover is replaced. Once in place, hold the bar still, replace sprocket cover (6). Make sure tool-free tension assembly bolt hole on the cover lines up with the bolt (18) in the main housing as shown in **Figure D**. Rotate the bar adjust locking knob (7) clockwise

until snug, then loosen knob one full turn, so the saw chain can be properly tensioned.

Note: If the cover does not fit correctly, check that the tab for the tool free tensioner on the bar aligns with the slot on the inside of the sprocket cover.



- While holding the bar adjust locking knob (7), rotate the chain tensioning knob (8) clockwise to increase tension as shown in **Figure E**. Make sure the saw chain (5) is snug around the guide bar (4).

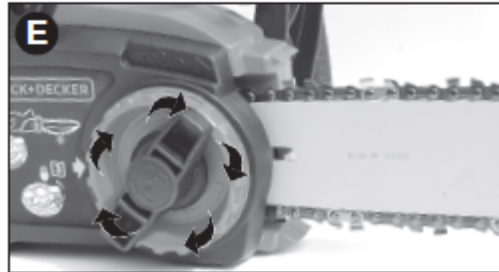

ADJUSTING CHAIN TENSION

⚠ CAUTION: Sharp chain. Always wear protective gloves when handling the chain. The chain is sharp and can cut you when it is not running.

⚠ WARNING: Sharp moving chain. To prevent accidental operation, ensure that battery is removed from the tool before performing the following operations. Failure to do this could result in serious personal injury.

- With the saw on a firm surface, check the saw chain (5) tension. The tension is correct when the chain snaps back after being pulled 1/8 inch (3mm) away from the guide bar (4) with light force from the middle finger and thumb as shown

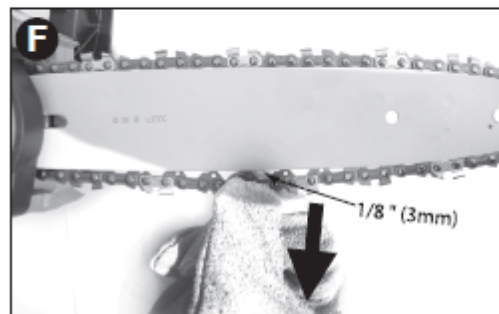

in **figure F**. There should be no “sag” between the guide bar and the chain on the underside as shown in **figure G**.

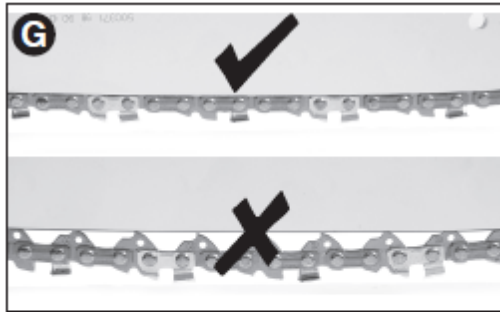

- To adjust saw chain tension, loosen bar adjust locking knob (7) one full turn and follow instructions for “Installing the Guide Bar and Saw Chain.”
- Do not over-tension the chain as this will lead to excessive wear and will reduce the life of the bar and chain.
- Once chain tension is correct, securely tighten bar adjust locking knob.
- When the chain is new, check the tension frequently (after removing battery) during the first 2 hours of use as a new chain stretches slightly.

REPLACING THE SAW CHAIN

⚠ CAUTION: Sharp chain. Always wear protective gloves when handling the chain. The chain is sharp and can cut you when it is not running.

⚠ WARNING: Sharp moving chain. To prevent accidental operation, ensure that battery is removed from the tool before performing the following operations. Failure to do this could result in serious personal injury.

- Rotate the bar adjust locking knob (7) counterclockwise to release chain tension.
- Remove sprocket cover (6) as described in “Installing the Guide Bar and Saw Chain” section.
- Lift the worn saw chain (5) out of the groove in the guide bar (4).
- Place the new chain in the slot of the guide bar, making sure the saw teeth are facing the correct direction by matching the arrow on the chain with the graphic on the sprocket cover (6) shown in **figure H**.

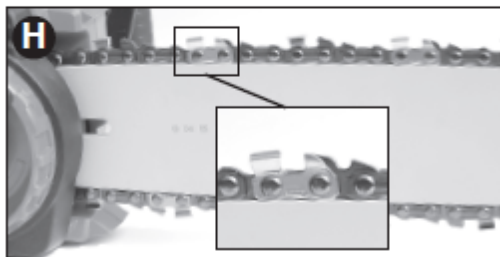

- Follow instructions for “Installing the Guide Bar and Saw Chain.”

Replacement chain and bar are available from your nearest Black+Decker service center.

- LCS1020 requires replacement chain # RC1000, service part number 90609782. Replacement 10” bar, service part number 90609787.
- LCS1240 requires replacement chain # RC1200, service part number 90609781. Replacement 12” bar, service part number 90609786.

SAW CHAIN AND GUIDE BAR OILING MANUAL OILING SYSTEM (20V ONLY)

This chain saw is equipped with a manual oiling system that keeps the saw chain and guide bar lubricated. Slowly press the primer bulb (15) on the oil cap (14) three times before making each cut. Hold the primer bulb down for 1 second each time. The oil level indicator (16) shows the level of the oil in the chain saw. If the oil level is less than a quarter full, remove the battery from the chain saw and refill with the correct type of oil.

AUTO OILING SYSTEM (40V ONLY)

This chain saw is equipped with an auto oiling system that keeps the saw chain and guide bar constantly lubricated. The oil level indicator (16) shows the level of the oil in the chain saw. If the oil level is less than a quarter full, remove the battery from the chain saw and refill with the correct type of oil.

NOTE: Use a high quality bar and chain oil for proper chain and bar lubrication. As a temporary substitute, a non-detergent SAE30 weight motor oil can be used. The use of a vegetable based bar and chain oil is recommended when pruning trees. Mineral oil is not recommended because it may harm trees. Never use waste oil or very thick oil. These may damage your chain saw.

FILLING THE OIL RESERVOIR

- Remove the oil cap (14) and fill the reservoir with the recommended chain oil until the oil level has reached the top of the oil level indicator (16).
- Refit the oil cap.
- Periodically switch the chain saw off and check the oil level indicator to ensure the bar and chain are being properly oiled.

TRANSPORTING SAW

- Always remove the battery from the tool and cover the guide bar (4) with the scabbard (9) (**figure I**) when transporting the saw.



OPERATING THE CHAIN SAW

⚠ WARNING: Read and understand all instructions. Failure to follow all instructions listed below may result in electric shock, fire and/or serious personal injury.

- **Guard Against Kickback which can result in severe injury or death.** See Important Safety Instructions "Guard Against Kickback", to avoid the risk of kickback.
- **Do not overreach. Do not cut above chest height. Make sure your footing is firm.** Keep feet apart. Divide your weight evenly on both feet.
- **Use a firm grip with your left hand on the front handle (11) and your right hand on the rear handle (10)** so that your body is to the left of the guide bar.
- **Do not hold chain saw by front hand guard (3).** Keep elbow of left arm locked so that left arm is straight to withstand a kickback.

⚠ WARNING: Never use a cross-handed grip (left hand on the rear handle and right hand on the front handle).

⚠ WARNING: Never allow any part of your body to be in line with the guide bar (4) when operating the chain saw.

- **Never operate while in a tree, in any awkward position or on a ladder or other unstable surface.** You may lose control of saw causing severe injury.
- **Keep the chain saw running at full speed the entire time you are cutting.**
- **Allow the chain to cut for you.** Exert only light pressure. Do not put pressure on chain saw at end of cut.

ON / OFF

- Always be sure of your footing and grip the chain saw firmly with both hands with the thumb and fingers encircling both handles.
- To turn the tool **ON**, depress the lock off button (2) and squeeze the trigger switch (1) as shown in **figure J**. (Once the tool is running you can release the lock off button.)
- To turn the tool **OFF**, release the trigger switch.



COMMON CUTTING TECHNIQUES

FELLING

The process of cutting down a tree. Be sure battery is fully charged before felling a tree so you can finish on a single charge. Do not fell trees in high wind conditions.

⚠ WARNING: Felling can result in injury. It should only be performed by a trained person.

- **(Figure K)** A retreat path should be planned and cleared as necessary before cuts are started. The retreat path should extend back and diagonally to the rear of the expected line of fall.

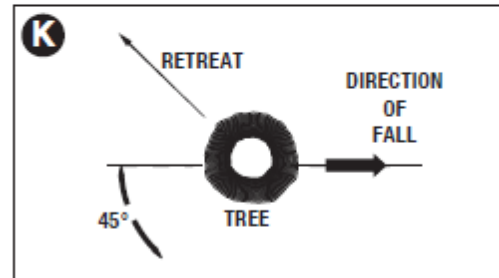

- Before felling is started, consider the natural lean of the tree, the location of larger branches and the wind direction to judge which way the tree will fall. Have wedges (wood, plastic or aluminum) and a heavy mallet handy. Remove dirt, stones, loose bark, nails, staples, and wire from the tree where the felling cuts are to be made.
- **Figure L - Notching Undercut -** Make the notch 1/3 of the diameter of the tree, perpendicular to the direction of the fall. Make the lower horizontal notching cut first. This will help to avoid pinching of either the saw chain or the guide bar when the second notch cut is being made.
- **(Figure L) Felling Back Cut -** Make the felling back cut at least 2 inches (51mm) higher than the horizontal notching cut. Keep the felling back cut parallel to the horizontal notching cut. Make the felling back cut so enough wood is left to act as a hinge. The hinge wood keeps the tree from twisting and falling in the wrong

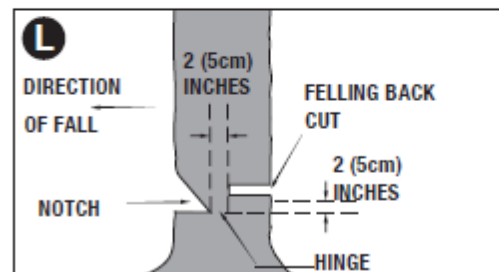

- direction. Do not cut through the hinge.
- **(Figure L)** As the felling cut gets close to the hinge the tree should begin to fall. If there is any chance that the tree may not fall in the desired direction or it may rock back and bind the saw chain, stop cutting before the felling cut is complete and use wedges to open the cut and drop the tree along the desired line of fall. When the tree begins to fall remove the chain saw from the cut, stop the motor, put the chain saw down, then use the retreat path planned. Be alert for overhead limbs falling and watch your footing.

LIMBING

Removing the branches from a fallen tree. When limbing, leave larger lower limbs to support the log off the ground. Remove the small limbs in one cut. Branches under tension should be cut from the bottom of the branch towards the top to avoid binding the chain saw as shown in **figure M**. Trim limbs from opposite side keeping tree stem between you and saw. Never make cuts with saw between your legs or straddle the limb to be cut.

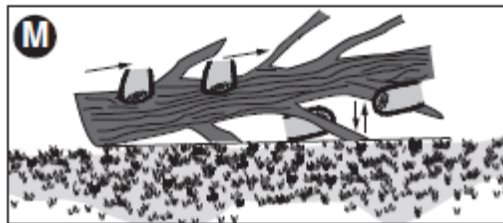

BUCKING

⚠ WARNING: Recommend that first time users should practice cutting on a saw horse.

Cutting a felled tree or log into lengths. How you should cut depends on how the log is supported. Use a saw horse (**figure N**) whenever possible. Always start a cut with the chain running at full speed.

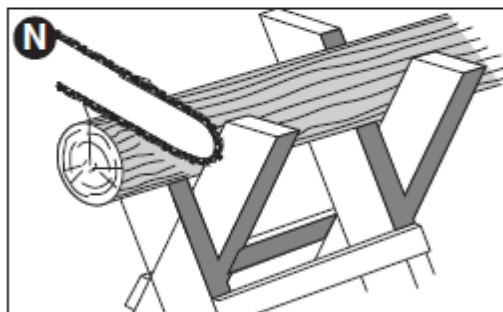

- Place the bottom spike (19) of the chain saw behind the area of the initial cut as shown in **figure O**.

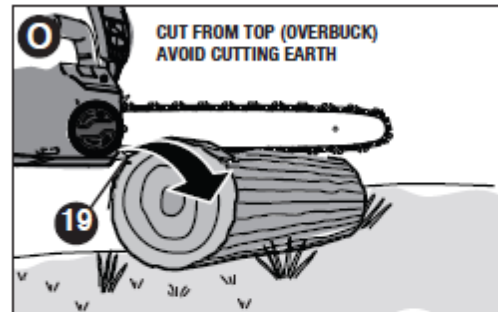

- Turn the chain saw on then rotate the chain and bar down into the tree, using the spike as a hinge.
- Once the chain saw gets to a 45 degree angle, level the chain saw again and repeat steps until you cut fully through.
- **When the tree is supported along its entire length**, make a cut from the top (overbuck), but avoid cutting the earth as this will dull your saw quickly.
- **Figure P- When supported at one end** First, cut 1/3 the diameter from the underside (underbuck). Then make the finished cut by overbucking to meet the first cut.

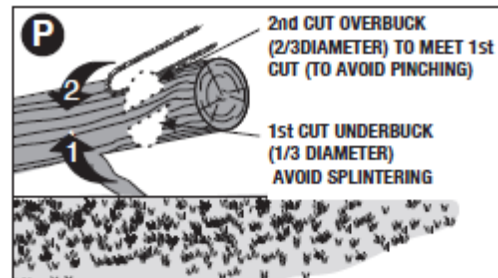

- **Figure Q- When supported at both ends** First, cut 1/3 down from the top overbuck. Then make the finished cut by underbucking the lower 2/3 to meet the first cut.

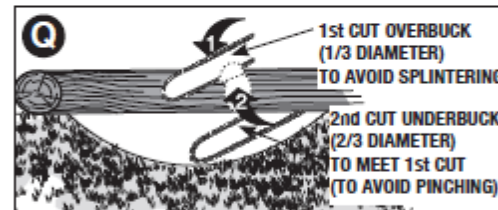

- **When on a slope** Always stand on the uphill side of the log. When "cutting through", to maintain complete control release the cutting pressure near the end of the cut without relaxing your grip on the chain saw handles. Don't let the chain contact the

ground. After completing the cut, wait for the saw chain to stop before you move the chain saw. Always stop the motor before moving from cut to cut.

CARE AND MAINTENANCE

Use only mild soap and damp cloth to clean the tool. Do not use solvents to clean the plastic housing of the saw. Never let any liquid get inside the tool; never immerse any part of the tool into a liquid.

IMPORTANT: To assure product SAFETY and RELIABILITY, repairs, maintenance and adjustment should be performed by authorized service centers or other qualified service organizations, always using identical replacement parts. Regular maintenance ensures a long effective life for your chain saw.

CHAIN AND BAR

After every few hours of use, remove the guide bar and chain and clean thoroughly using a soft bristle brush. Ensure oiling hole on bar is clear of debris.

SAW CHAIN SHARPENING

⚠ CAUTION: Sharp chain. Always wear protective gloves when handling the chain. The chain is sharp and can cut you when it is not running.

⚠ WARNING: Sharp moving chain. To prevent accidental operation, ensure that battery is removed from the tool before performing the following operations. Failure to do this could result in serious personal injury.

NOTE: The cutters will dull immediately if they touch the ground or a nail while cutting.

To get the best possible performance from your chain saw it is important to keep the teeth of the chain sharp. Follow these helpful tips for proper saw chain sharpening:

1. For best results use a 4.5mm file and a file holder or filing guide to sharpen your chain. This will ensure you always get the correct sharpening angles.
2. Place the file holder flat on the top plate and depth gauge of the cutter.
3. **(Figure R)** Keep the correct top plate (20) filing angle line of 30° on your file guide parallel with your chain (file at 60° from chain viewed from above).
4. Sharpen cutters on one side of the chain first. File from the inside of

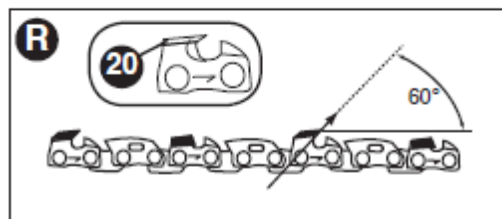

each cutter to the outside. Then turn your saw around and repeat the processes (2,3,4) for cutters on the other side of the chain.

NOTE: Use a flat file to file the tops of the rakers (portion of chain link in front of the cutter) so they are about .025 inch (.635 mm) below the tips of the cutters as shown in **Figure S**.

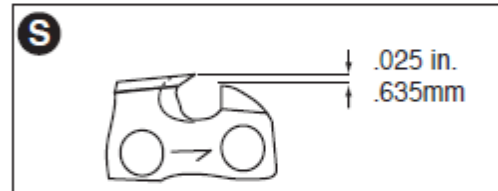

5. **Figure T-** Keep all cutter lengths equal.

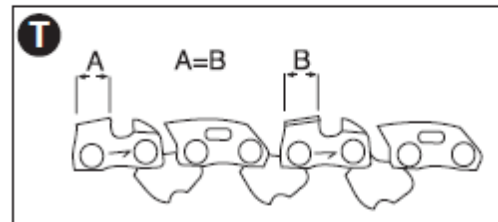

6. If damage is present on the chrome surface of the top plates or side plates, file back until such damage is removed.

⚠ CAUTION: After filing, the cutter will be sharp, use extra caution during this process.

NOTE: Each time the chain is sharpened, it loses some of the low kickback qualities and extra caution should be used. It is recommended that a chain be sharpened no more than four times.

ACCESSORIES

⚠ WARNING: The use of accessories not recommended in this manual may be hazardous.

Replacement chain and bar are available from your nearest Black+Decker service center.

- LCS1020 requires replacement chain # RC1000, service part number 90609782. Replacement 10" bar, service part number 90609787.
- LCS1240 requires replacement chain # RC1200, service part number 90609781. Replacement 12" bar, service part number 90609786.

The use of accessories not recommended in this manual may be hazardous.

TROUBLESHOOTING

If your Chain Saw does not operate correctly check the following:

<u>Problem</u>	<u>Possible Cause</u>	<u>Possible Solution</u>
<ul style="list-style-type: none">• Tool will not start.	<ul style="list-style-type: none">• Battery not installed properly.• Battery not charged.• Lock-out button not actuated.	<ul style="list-style-type: none">• Check battery installation.• Check battery charging requirements.• Push lock off button/actuate trigger.
<ul style="list-style-type: none">• Unit will not charge.	<ul style="list-style-type: none">• Battery not inserted into charger.	<ul style="list-style-type: none">• Insert battery into charger until green LED appears. Charge up to 5 hours if battery totally drained.
<ul style="list-style-type: none">• Bar / chain overheated.	<ul style="list-style-type: none">• Chain too tight.• Lubrication needed.	<ul style="list-style-type: none">• Refer to “adjusting chain tension” section.• Refer to “chain oiling” section.
<ul style="list-style-type: none">• Chain is loose.	<ul style="list-style-type: none">• Chain tension set incorrectly.	<ul style="list-style-type: none">• Refer to “adjusting chain tension” section.
<ul style="list-style-type: none">• Poor cut quality.	<ul style="list-style-type: none">• Chain tension set incorrectly.• Chain needs replacement.	<ul style="list-style-type: none">• Refer to “adjusting chain tension” section. <p>Note: Excessive tension leads to excessive wear and reduction in life of bar & chain. Lubricate before each cut. Refer to “replacing the chain” section.</p>
<ul style="list-style-type: none">• Unit runs but does not cut.	<ul style="list-style-type: none">• Chain installed backwards.	<ul style="list-style-type: none">• Refer to sections for installing and removing chain.
<ul style="list-style-type: none">• Unit stops while cutting.	<ul style="list-style-type: none">• Lithium battery depleted.• Voltage limit protection exceeded.• Battery too hot.	<ul style="list-style-type: none">• Charge battery.• Unit is being forced. Restart and apply less pressure.• Allow battery to cool for 30 minutes before proceeding.
<ul style="list-style-type: none">• Unit does not oil.	<ul style="list-style-type: none">• Oil reservoir emptied.• Oiling hole on guide bar clogged.	<ul style="list-style-type: none">• Refill reservoir.• Clean guide bar, sprocket and sprocket cover. Refer to “care and maintenance” section.

For assistance with your product, visit our website www.blackanddecker.com for the location of the service center nearest you or call the BLACK+DECKER help line at **1-800-544-6986**.

SERVICE INFORMATION

All BLACK+DECKER Service Centers are staffed with trained personnel to provide customers with efficient and reliable power tool service. Whether you need technical advice, repair, or genuine factory replacement parts, contact the BLACK+DECKER location nearest you. To find your local service location, call: **1-800-544-6986**, or visit www.blackanddecker.com

THE RBRC™ SEAL

The RBRC™ (Rechargeable Battery Recycling Corporation) Seal on the Li-Ion battery (or battery pack) indicates that the costs to recycle the battery (or battery pack) at the end of its useful life have already been paid by Black+Decker. RBRC™ in cooperation with Black+Decker and other battery users, has established programs in the United States to facilitate the collection of spent Li-Ion batteries. Help protect our environment and conserve natural resources by returning the spent Li-Ion battery to an authorized Black+Decker service center or to your local retailer for recycling. You may also contact your local recycling center for information on where to drop off the spent battery. RBRC™ is a registered trademark of the Rechargeable Battery Recycling Corporation.



This Class B digital apparatus complies with Canadian ICES-003.

This device complies with part 15 of the FCC rules. Operation is subject to the following two conditions: (1) This device may not cause harmful interference, and (2) this device must accept any interference received, including interference that may cause undesired operation.

NOTE: This equipment has been tested and found to comply with the limits for a Class B digital device, pursuant to Part 15 of the FCC Rules. These limits are designed to provide reasonable protection against harmful interference in a residential installation. This equipment generates, uses and can radiate radio frequency energy and, if not installed and used in accordance with the instructions, may cause harmful interference to radio communications. However, there is no guarantee that interference will not occur in a particular installation.

If this equipment does cause harmful interference to radio or television reception, which can be determined by turning the equipment off and on, the user is encouraged to try to correct the interference by one or more of the following measures:

- Reorient or relocate the receiving antenna.
- Increase the separation between the equipment and receiver.
- Connect the equipment into an outlet on a circuit different from that to which the receiver is connected.
- Consult the dealer or an experienced radio/TV technician for help.

Changes or modifications to this unit not expressly approved by the party responsible for compliance could void the user's authority to operate the equipment. This Class B digital apparatus complies with Canadian ICES-003.

LIMITED WARRANTY

TWO-YEAR (LCS1020 ONLY)

THREE-YEAR (LCS1240 ONLY)

Black+Decker (U.S.) Inc. warrants this product to be free from defects in material or workmanship for a period of two (2) years for LCS1020 and three (3) years for LCS1240 following the date of purchase, provided that the product is used in a home environment. This limited warranty does not cover failures due to abuse, accidental damage or when repairs have been made or attempted by anyone other than Black+Decker and its Authorized Service Centers. A defective product meeting the warranty conditions set forth herein will be replaced or repaired at no charge in either of two ways:

The first, which will result in exchanges only, is to return the product to the retailer from whom it was purchased (provided that the store is a participating retailer). Returns should be made within the time period of the retailer's policy for exchanges. Proof of purchase may be required. Please check with the retailer for its specific return policy regarding time limits for returns or exchanges. The second option is to take or send the product (prepaid) to a Black+Decker owned or authorized Service Center for repair or replacement at Black+Decker's option. Proof of purchase may be required. Black+Decker owned and authorized service centers are listed online at www.blackanddecker.com.

This warranty does not apply to accessories. This warranty gives you specific legal rights and you may have other rights which vary from state to state. Should you have any questions, contact the manager of your nearest Black+Decker Service Center. This product is not intended for commercial use, and accordingly, such commercial use of this product will void this warranty. All other guarantees, express or implied, are hereby disclaimed.

LATIN AMERICA: This warranty does not apply to products sold in Latin America. For products sold in Latin America, check country specific warranty information contained in the packaging, call the local company or see the website for such information.

Imported by
Black+Decker (U.S.) Inc.,
701 E. Joppa Rd.
Towson, MD 21286 U.S.A.

