



PARTS BREAKDOWN

DCS6421 (Makita Teal)

DCS6421R (Makita Red)

PS-6400 (Dolmar Red)

PS-6400H (Dolmar Red)

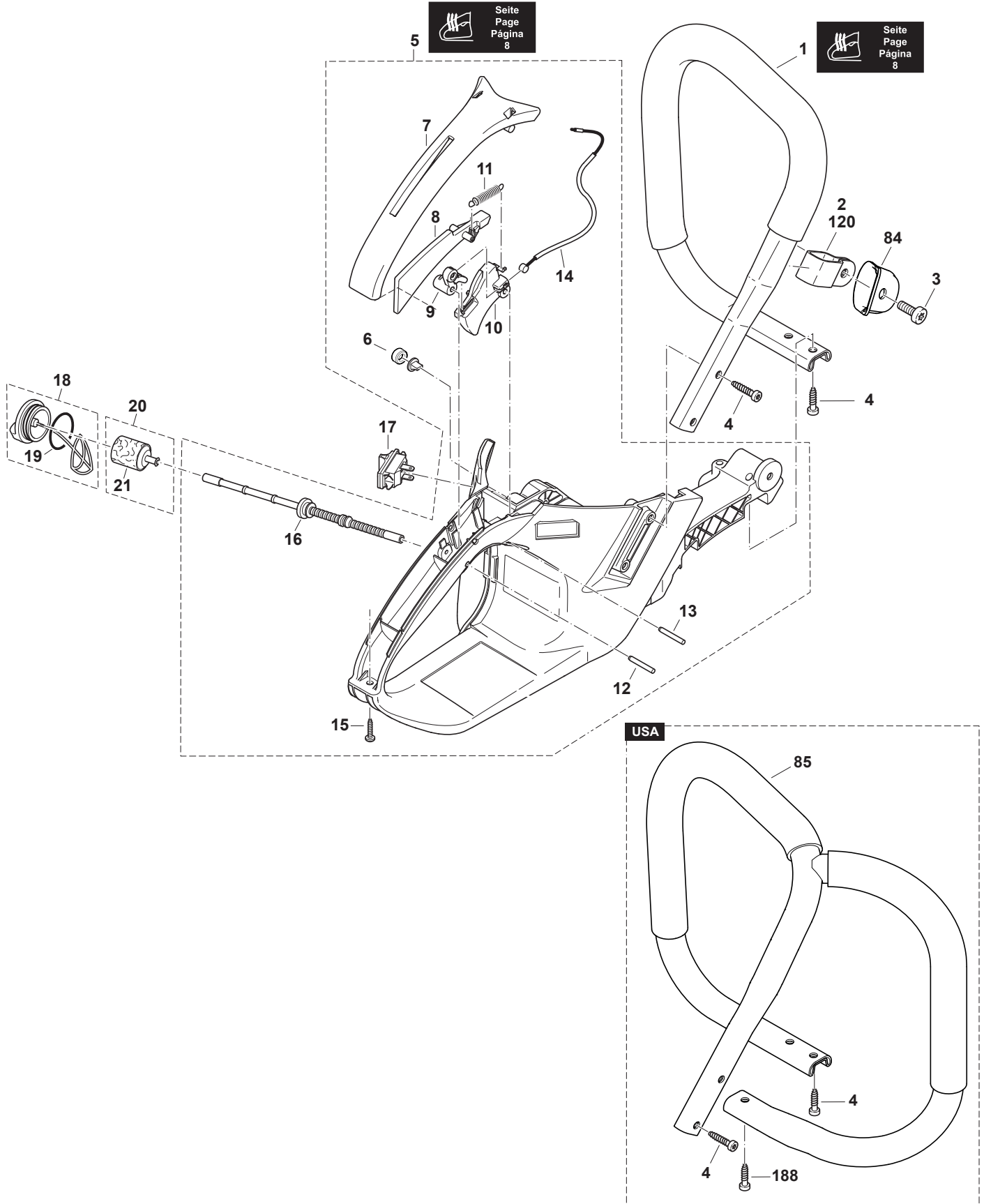

Products with multiple versions are listed in subsiding order with the newest version on top not indented.

Section	Fig. No.	Part No.	Description	DCS642120	DCS6421R	PS-6400	PS-6400H	Tech Bulletin	Notes
1	1	038-310-021	TUBULAR HANDLE ASSY	1	1	1			
1	1	038-310-020	TUBULAR HANDLE ASSY	1		1			
1	2	038-310-062	CLAMP, DCS6401	1	1	1	1		
1	2	038-310-061	CLAMP, DCS6401	1		1	1		
1	3	908-006-145	SCREW 6x14	1	1	1	1		
1	4	913-455-164	SCREW 5.5x16	4		4	4		
1	5	038-114-700	TANK CPL. BLUE, DCS6401	1					USA (EPA)
1	5	038-114-609	TANK CPL. BLUE, DCS6401	1					USA (EPA)
1	5	038-114-200	TANK CPL. RED		1	1			USA (EPA)
1	6	957-114-061	AIR VALVE CPL, DCS6401	1	1	1	1		
1	7	038-114-631	GRIP PLATE BLUE	1					
1	7	038-114-630	GRIP PLATE, BLUE	1					
1	7	038-114-031	GRIP PLATE RED		1	1	1		
1	8	038-117-020	CATCH LEVER	1	1	1	1		
1	9	038-117-030	ROCKER	1	1	1	1		
1	10	038-117-010	THROTTLE LEVER	1	1	1	1		
1	11	038-117-050	SPRING	1	1	1	1		
1	12	935-930-240	CYLINDRICAL PIN 3x24	1	1	1	1		
1	13	935-930-280	CYLINDRICAL PIN 3x28	1	1	1	1		
1	14	038-117-041	BOWDEN CABLE, DCS6421	1	1	1	1		
1	14	010-117-040	BOWDEN CABLE	1		1	1		
1	15	913-340-204	SCREW 4x20 S27	1	1	1	1		
1	16	038-114-052	FUEL LINE, DCS6421	1	1	1	1		
1	16	038-114-051	FUEL LINE, DCS6401	1		1	1		
1	17	975-001-241	SHORT CIRCUIT SWITCH, DCS6401	1	1	1	1		
1	18	010-114-050	TANK CAP cpl.	1	1	1	1		
1	19	963-228-030	PACKING RING 28x3	1	1	1	1		
1	20	010-114-010	SUCTION HEAD	1	1	1	1		
1	20	963-601-122	SUCTION HEAD CPL., DPC7321	1		1	1		
1	21	963-601-240	FELT for SUCTION HEAD	1	1	1	1		For use with 963-601-122
1	21	010-114-020	SUCTION HEAD REPAIR KIT	1	1	1	1		For use with 010-114-010
1	84	038-310-070	SPRING LIMITER, DCS6421	1	1	1	1		
1	85	038-310-111	WRAP AROUNDHANDLE ASSY.	1	1	1	1		
1	120	010-114-039	SET OF SPRINGS, DCS6421	1	1	1	1		Inc. 2, 70, 88, 90, 93
1	188	913-455-164	SCREW 5.5x16	1	1	1	1		

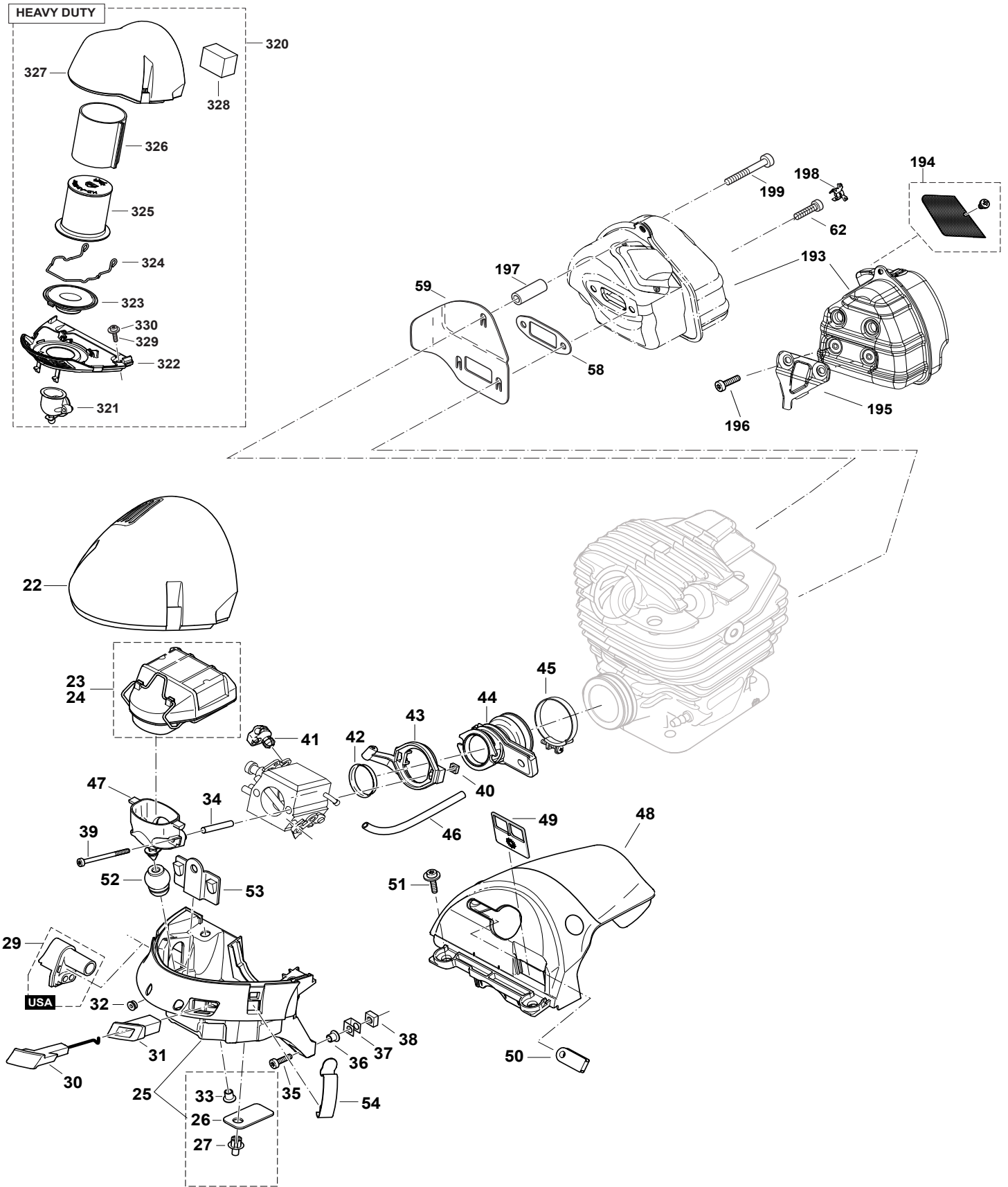

Products with multiple versions are listed in subsiding order with the newest version on top not indented.

Section	Fig. No.	Part No.	Description	DCS642120	DCS6421R	PS-6400	PS-6400H	Tech Bulletin	Notes
2	22	038-118-024	COVER BLACK	1	1	1	1		
2	23	038-173-101	AIR FILTER CPL., DCS6401	1	1	1	1		
2	24	038-173-011	AIR FILTER COMPLETE, NYLON, DCS6401	1	1	1	1		
2	25	038-118-670	BOTTOM BLUE, DCS6401	1					
2	25	038-118-630	BOTTOM, BLUE	1					
2	25	038-118-170	BOTTOM RED		1	1	1		
2	26	038-118-110	RUBBER FLAP	2	2	2	2		
2	27	938-650-062	RIVET	2	2	2	2		
2	29	038-118-083	ADJUSTING GUIDE, DCS6421	1	1	1	1		2009-10>
2	29	038-118-081	ADJUSTING GUIDE, DCS6421			1	1		>2009-09
2	30	038-155-052	CHOKE LINKAGE, DCS6401	1	1	1	1		
2	30	038-155-051	CHOKE SHAFT, DCS6401	1		1	1		
2	31	038-155-020	CHOKE GUIDE	1	1	1	1		
2	33	001-118-100	BUSHING	2	2	2	2		
2	34	038-155-060	SPACER L=30MM	2	2	2	2		
2	35	908-005-205	SCREW 5x20	2	2	2	2		
2	36	001-118-100	BUSHING	2	2	2	2		
2	37	038-111-050	CLIP	2	2	2	2		
2	38	038-111-060	SQUARE NUT M5	2	2	2	2		
2	39	908-204-555	SCREW 4x55	2	2	2	2		
2	40	921-804-004	SQUARE NUT M4	2	2	2	2		
2	41	038-155-012	RETAINING CLIP, DCS6401	1	1	1	1		
2	42	038-131-031	INSERT FOR SUCTION HOSE, DCS6401	1	1	1	1		
2	43	038-171-041	FLANGE	1	1	1	1		
2	44	038-131-011	SUCTION HOSE, DCS6401	1	1	1	1		
2	45	965-603-050	HOSE CLAMP	1	1	1	1		
2	46	965-452-382	TUBE,	1	1	1	1		
2	46	965-452-380	TUBE,L=65	1		1	1		
2	47	038-171-012	CONNECTING MUFF, DCS7901	1	1	1	1		
2	47	038-171-011	CONNECTING MUFF, DCS7901	1	1	1	1		
2	48	038-118-050	HOOD CPL. BLACK, DCS6421	1	1	1	1	2012-01	2012-01>
2	48	038-118-291	HOOD CPL.BLACK			1	1		>2011-12
2	49	038-118-140	INSERT	1	1	1	1		
2	50	038-118-130	CABLE GUIDE	1	1	1	1		
2	51	917-105-205	SCREW M5x20	2	2	2	2		

Products with multiple versions are listed in subsiding order with the newest version on top not indented.

Section	Fig. No.	Part No.	Description	DCS642120	DCS6421R	PS-6400	PS-6400H	Tech Bulletin	Notes
2	52	038-171-031	HOLDER	1	1	1	1		
2	53	038-118-100	PLUG	1	1	1	1		
2	54	130-118-070	STEEL CLIP, DCS6401	2	2	2	2		
2	54	038-118-071	STEEL CLIP	2		2	2		
2	58	038-174-811	GASKET, DPC8112	1	1	1	1		
2	59	038-174-023	COVER PLATE, DCS6401	1	1	1	1		
2	59	038-174-021	COVER PLATE, DCS6401	1		1	1		
2	62	908-405-205	SCREW M5x20	2	2	2	2		
2	193	038-174-300	MUFFLER, DCS6421	1	1	1	1		
2	194	038-174-910	SPARK ARRESTOR SCREEN, DCS6421	1	1	1	1		2010-01>
2	195	038-174-400	CARRIER FOR CATALYST	1	1	1	1		2010-01>
2	196	909-005-105	SCREW M5X10, DCS6421	2	2	2	2		2010-01>
2	197	038-174-410	CONNECTING LINK, DCS6421	1	1	1	1		2010-01>
2	198	038-174-451	PLUG FOR MUFFLER TUBE, DCS6421	2	2	2	2		2010-01>
2	199	908-505-555	TORX SCREW 5X55, EHW120	1	1	1	1		2010-01>
2	320	957-173-400	HEAVY DUTY AIR FILTER KIT	1	1	1	1		ACCESSORY ONLY
2	321	038-171-050	CONNECTING MUFF	1	1	1	1		ACCESSORY ONLY
2	322	038-118-460	INTERMEDIATE BOTTOM	1	1	1	1		ACCESSORY ONLY
2	323	038-118-490	BELLOWS	1	1	1	1		ACCESSORY ONLY
2	324	038-118-450	CLIP FOR BOW	1	1	1	1		ACCESSORY ONLY
2	325	038-173-310	AIR-FILTER CARTRIDGE	1	1	1	1		ACCESSORY ONLY
2	326	038-173-350	PRE-FILTER	1	1	1	1		ACCESSORY ONLY
2	327	038-118-410	COVER	1	1	1	1		ACCESSORY ONLY
2	328	038-173-370	PRE-FILTER	1	1	1	1		ACCESSORY ONLY
2	329	908-405-255	SCREW	1	1	1	1		ACCESSORY ONLY
2	330	924-805-310	DISC	1	1	1	1		ACCESSORY ONLY

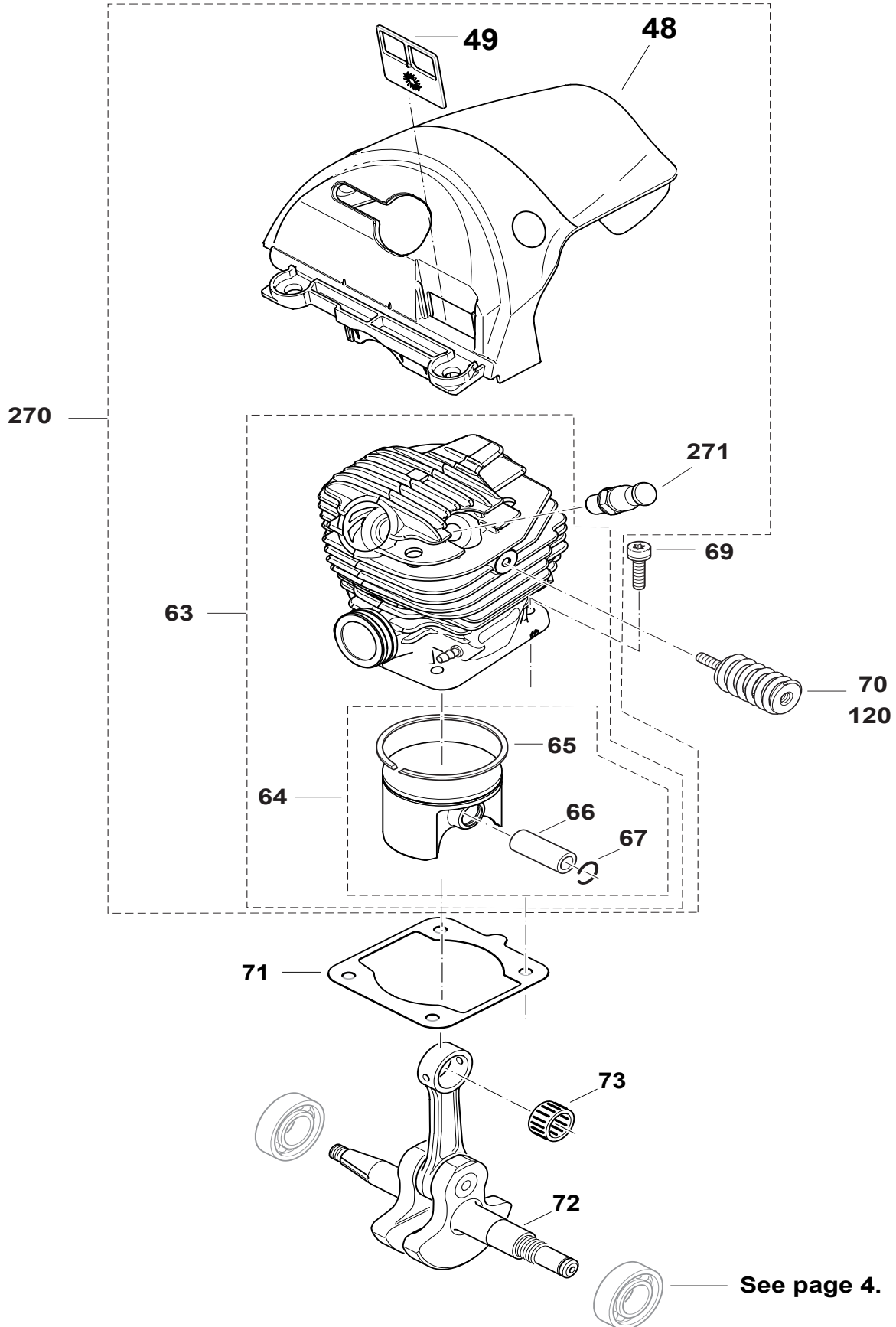

Products with multiple versions are listed in subsiding order with the newest version on top not indented.

Section	Fig. No.	Part No.	Description	DCS642120	DCS6421R	PS-6400	PS-6400H	Tech Bulletin	Notes
3	48	038-118-050	HOOD CPL., BLACK, DCS6421	1	1	1	1	2012-01	
3	49	038-118-140	INSERT	1	1	1	1		
3	63	040-130-035	CYLINDER PISTON CPL., DCS6421	1	1	1	1	2012-01	
3	64	325-132-034	PISTON CPL., DCS6421	1	1	1	1		
3	64	325-132-033	PISTON CPL. (47), DPC6410	1		1	1		
3	65	325-132-050	PISTON RING (D=47)	1	1	1	1		
3	66	119-132-030	PISTON PIN	1	1	1	1		
3	67	038-132-080	SPRING RING C12x1	2	2	2	2		
3	69	908-805-235	SCREW W/SPRING WASHER, DPC7331	4	4	4	4		
3	70	181-114-401	SPRING W/THREADED INSERT, DCS6401	1	1	1	1		
3	70	038-114-152	SPRING W/THREADED INSERT, DCS6401	1		1	1		
3	71	965-531-160	GASKET, DPC6410	1	1	1	1		
3	72	038-120-100	CRANKSHAFT CPL., DCS6421	1	1	1	1		
3	72	038-120-021	CRANKSHAFT, DCS6401	1		1	1		
3	73	962-210-121	NEEDLE CAGE, DCS6421	1	1	1	1		
3	73	962-210-019	NEEDLE CAGE	1		1	1		
3	120	010-114-039	SET OF SPRINGS, DCS6421	1	1	1	1		Inc. 2, 70, 88, 90, 93
3	270	040-130-910	REPLACEMENT CYLINDER SET, PS-6400	1	1	1	1	2012-01	Inc. 48, 49, 64, 271
3	271	038-118-180	DECOMPRESSION VALVE	1	1	1	1	2012-01	

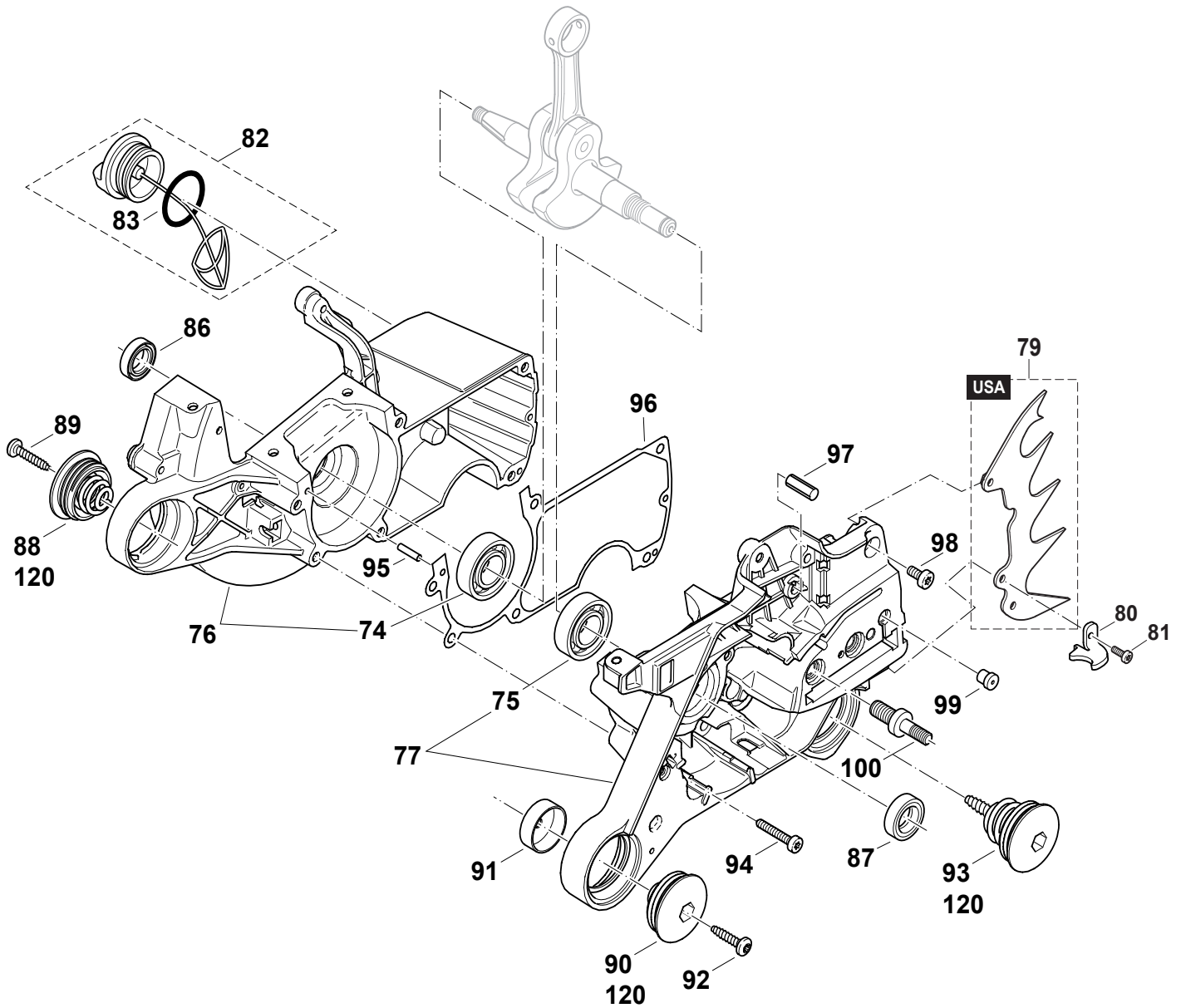

Products with multiple versions are listed in subsiding order with the newest version on top not indented.

Section	Fig. No.	Part No.	Description	DCS642120	DCS6421R	PS-6400	PS-6400H	Tech Bulletin	Notes
4	74	960-102-152	BALL BEARING, DCS6421	1	1	1	1		
4	74	960-102-159	BALL BEARING 6202	1		1	1		
4	75	960-102-179	BALL BEARING 6203 C4	1	1	1	1		
4	76	038-111-660	CRANKCASE MAG.SIDE-BLUE, DCS6401	1					
4	76	038-111-160	CRANKCASE MAG. SIDE RED		1	1			
4	77	038-111-641	CRANKCASE CLUTCH SIDE,BLUE, DCS6401	1					
4	77	038-111-270	CRANKCASE CLUTCH SIDE RED		1	1	1		
4	77	038-111-141	CRANKCASE CLUTCH SIDE RED			1	1		
4	79	038-250-222	SPIKE BAR (CRANKCASE), DCS6421	1	1	1	1		
4	79	038-250-221	SPIKE BAR (CRANKCASE), DCS6421	1		1	1		
4	79	038-250-202	SPIKE BAR (CRANKCASE), DCS6421	1		1	1		
4	79	038-250-201	SPIKE BAR (CRANKCASE), DCS6401	1		1	1		
4	80	038-111-171	CHAIN CATCH, DCS6401	1	1	1	1		
4	81	908-805-205	SCREW 5x16	1	1	1	1		
4	82	010-114-050	TANK CAP cpl.	1	1	1	1		
4	83	963-228-030	PACKING RING 28x3	1	1	1	1		
4	86	962-900-052	RADIAL RING	1	1	1	1		
4	87	962-900-061	RADIAL RING 17x28x5/4	1	1	1	1		
4	88	038-114-130	SPRING cpl.,w/cap	1	1	1	1		
4	89	913-455-204	SCREW 5.5x20	1	1	1	1		
4	90	038-114-130	SPRING cpl.,w/cap	1	1	1	1		
4	91	038-114-191	POT, DCS6401	1	1	1	1		
4	91	038-114-190	POT	1		1	1		
4	92	913-455-204	SCREW	1	1	1	1		
4	93	038-114-141	SPRING, DCS6401	1	1	1	1		
4	94	908-005-305	SCREW 5x30	6	6	6	6		
4	95	936-430-160	SPIRAL CLAMPING PIN 3x16	2	2	2	2		
4	96	038-111-042	GASKET	1	1	1	1		
4	97	934-660-250	SLOTTED PIN 6x24	1	1	1	1		
4	98	908-105-126	FLAT HEAD SCREW M5X12, DCS460	1	1	1	1		2015-01>
4	98	908-005-125	SCREW 5X12	1	1	1	1		>2014-12
4	99	168504-9	VENT VALVE	1	1	1	1		
4	99	010-245-030	VENT VALVE	1		1	1		
4	100	038-232-011	FASTENING BOLT, DCS6421	2	2	2	2		
4	100	038-232-010	BOLT	2		2	2		
4	120	010-114-039	SET OF SPRINGS, DCS6421	1	1	1	1		Inc. 2, 70, 88, 90, 93

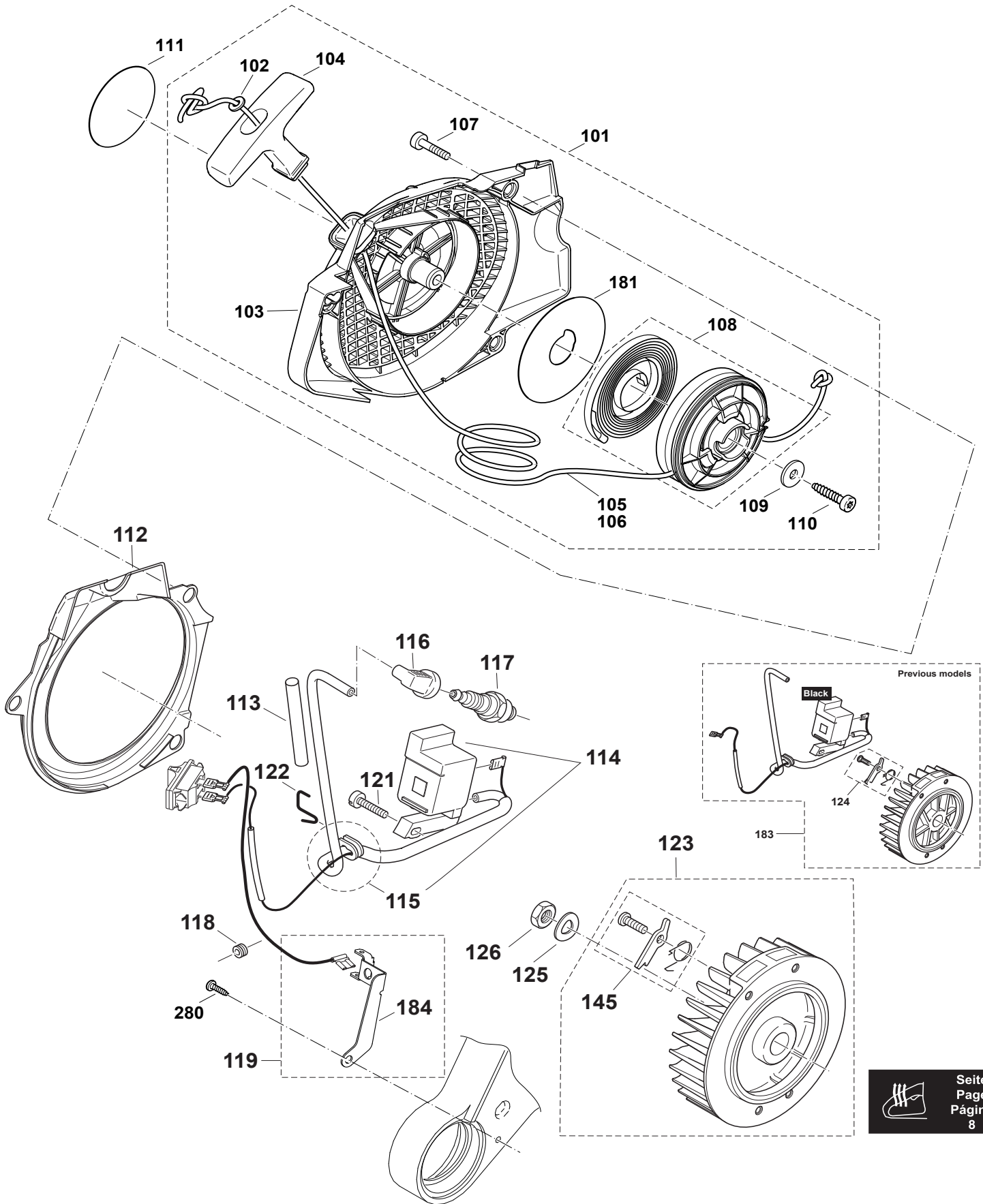

Seite
Page
Página
8

Products with multiple versions are listed in subsiding order with the newest version on top not indented.

Section	Fig. No.	Part No.	Description	DCS642120	DCS6421R	PS-6400	PS-6400H	Tech Bulletin	Notes
5	101	038-160-610	STARTER ASS'Y. BLUE, DCS6421	1					
5	101	038-160-604	STARTER ASS'Y., DCS6401	1					
5	101	038-160-010	STARTER ASSY. RED		1	1	1		
5	102	928-405-000	SPRING WASHER	1	1	1	1		
5	103	038-112-630	FAN HOUSING, BLUE	1					
5	103	038-112-032	FAN HOUSING RED		1	1	1		
5	104	001-161-020	STARTER GRIP, DPC6410	1	1	1	1		
5	105	108-164-020	STARTER ROPE,(L=980MM)	1	1	1	1		
5	106	985-000-155	STARTER ROPE, (L=100M)	1	1	1	1		ACCESSORY ONLY
5	107	908-605-205	SCREW M5x20	3	3	3	3		
5	108	038-162-024	CABLE DRUM, DCS6401	1	1	1	1		
5	109	924-605-510	WASHER 5.5x18x1.6	1	1	1	1		
5	110	913-455-204	SCREW 5.5x20	1	1	1	1		
5	111	980-115-674	LABEL, PS6400			1	1		
5	111	980-115-539	LABEL, DCS6421	1					
5	112	038-112-020	AIR DUCT	1	1	1	1		
5	113	970-502-110	INSULATING HOSE,L=140	1	1	1	1		
5	114	038-143-041	IGNITION COIL RED, DCS6401H	1	1	1	1		
5	115	038-143-030	CABLE HARNESS	1	1	1	1		
5	116	957-604-240	PLUG CAP	1	1	1	1		
5	117	965-603-021	SPARK PLUG	1	1	1	1		
5	118	965-401-011	RUBBER BUSH	1	1	1	1		
5	119	970-311-540	EARTH CABLE			1	1		>2010-09
5	119	957-311-590	EARTH CABLE, DCS6421	1	1	1	1		Inc. 184 2010-10>
5	121	908-304-205	SCREW 4x10x20 S27	2	2	2	2		
5	122	038-111-110	CLIP	2	2	2	2		
5	123	957-141-000	FLYWHEEL, DCS6401	1	1	1	1		
5	123	038-141-000	FLYWHEEL ASSY.	1		1	1		
5	124	108-166-051	STARTER RATCHET cpl.			2	2		
5	125	267822-3	SPRING WASHER	1	1	1	1		
5	125	926-208-001	SPRING WASHER	1		1	1		
5	126	920-208-024	HEXAGONAL NUT M8x1	1	1	1	1		>2010-09
5	145	038-166-050	STARTER RACHET CPL. PS-7910	1	1	1	1		2010-10>
5	181	038-162-050	SPACER	1	1	1	1		
5	183	010-038-141	FLYWHEEL/IGNITION COIL KIT, DCS6401			1			
5	184	038-111-150	CLAMP, PS-7910	1	1	1	1		
5	280	251480-5	SCREW BZ3.5x9.5	1	1	1	1		

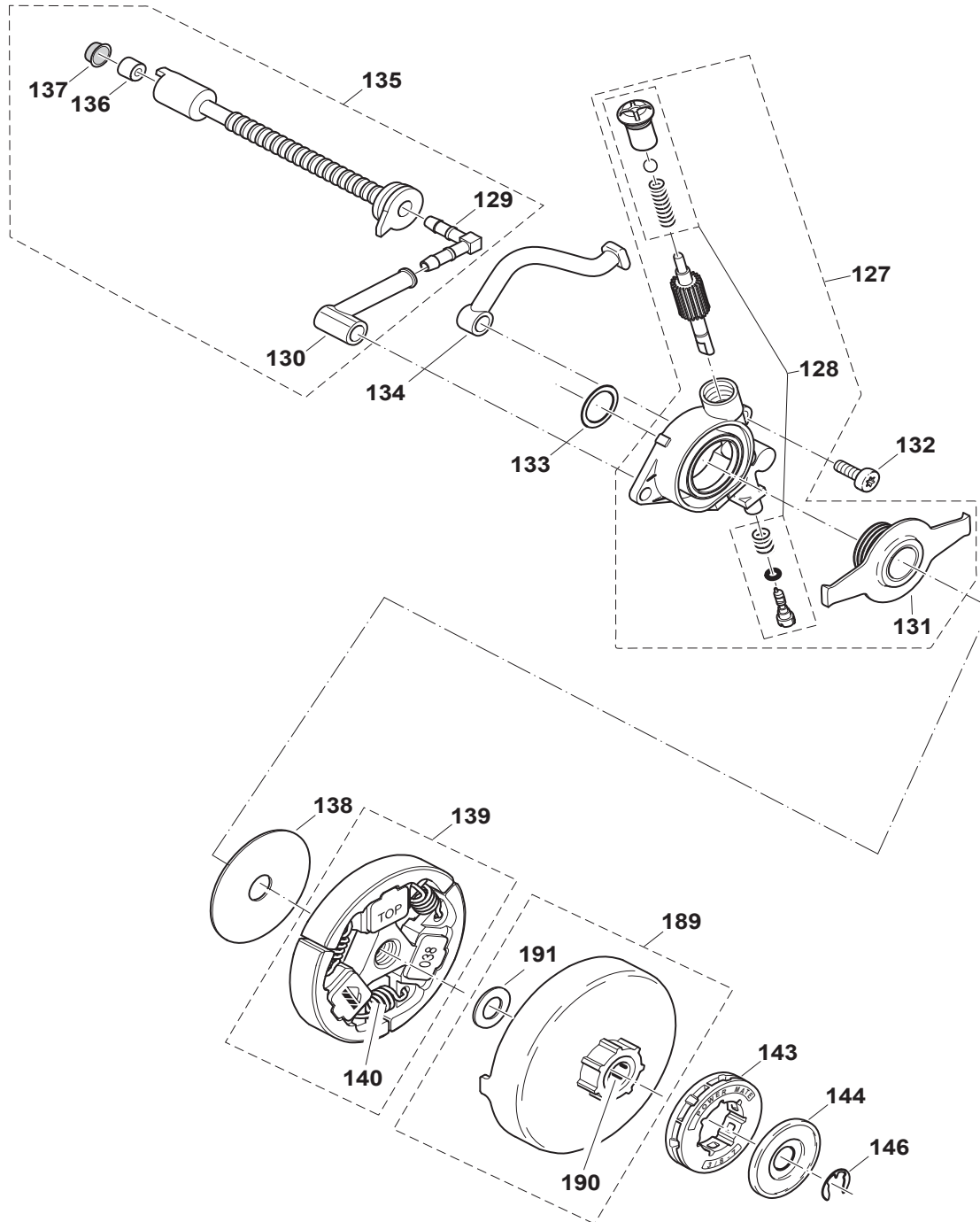

Products with multiple versions are listed in subsiding order with the newest version on top not indented.

Section	Fig. No.	Part No.	Description	DCS642120	DCS6421R	PS-6400	PS-6400H	Tech Bulletin	Notes
6	127	038-245-011	OIL PUMP CPL., DCS6401	1	1	1	1		
6	128	030-245-070	REPAIR KIT	1	1	1	1		
6	129	001-245-140	ANGULAR NIPPLE	1	1	1	1		
6	130	038-245-110	OIL LINE	1	1	1	1		
6	131	038-245-031	PUMP DRIVE, DCS6401	1	1	1	1		
6	132	908-005-125	SCREW 5x12	2	2	2	2		
6	133	038-224-021	DISC, DCS6401	1	1	1	1		
6	134	038-245-061	OIL LINE, DCS6401	1	1	1	1		
6	135	038-245-020	SUCTION LINE OIL cpl.	1	1	1	1		
6	136	900-005-066	DISTANCE RING	1	1	1	1		
6	137	963-601-100	STRAINER SCREEN	1	1	1	1		
6	138	001-182-042	GUIDE DISC, DCS6401	1	1	1	1		
6	139	038-180-013	CLUTCH ASS'Y, DCS6421	1	1	1	1		
6	139	038-180-012	CLUTCH ASS'Y, DCS6421	1	1	1	1		
6	139	038-180-011	CLUTCH ASS'Y, DCS6401	1		1	1		
6	140	024-184-021	SPRING	3	3	3	3		
6	142	962-210-024	NEEDLE SLEEVE, DCS510	1	1	1	1	2005-12	
6	143	119-224-070	RIM SPROCKET, T=3/8"	1	1	1	1		
6	144	267820-7	WASHER 29, EA4300F	1	1	1	1		
6	144	181-224-081	DISC, DCS510	1	1	1	1		
6	146	259045-7	STOP RING E-8, EA4300F	1	1	1	1		
6	146	927-408-000	WASHER, D=8x1.3	1	1	1	1		
6	189	957-223-092	CLUTCH DRUM CPL., DCS6401	1	1	1	1		Inc. 190,191
6	190	962-300-009	NEEDLE SLEEVE, DCS510	1	1	1	1		
6	191	038-223-100	WASHER, PS-7910	1	1	1	1		

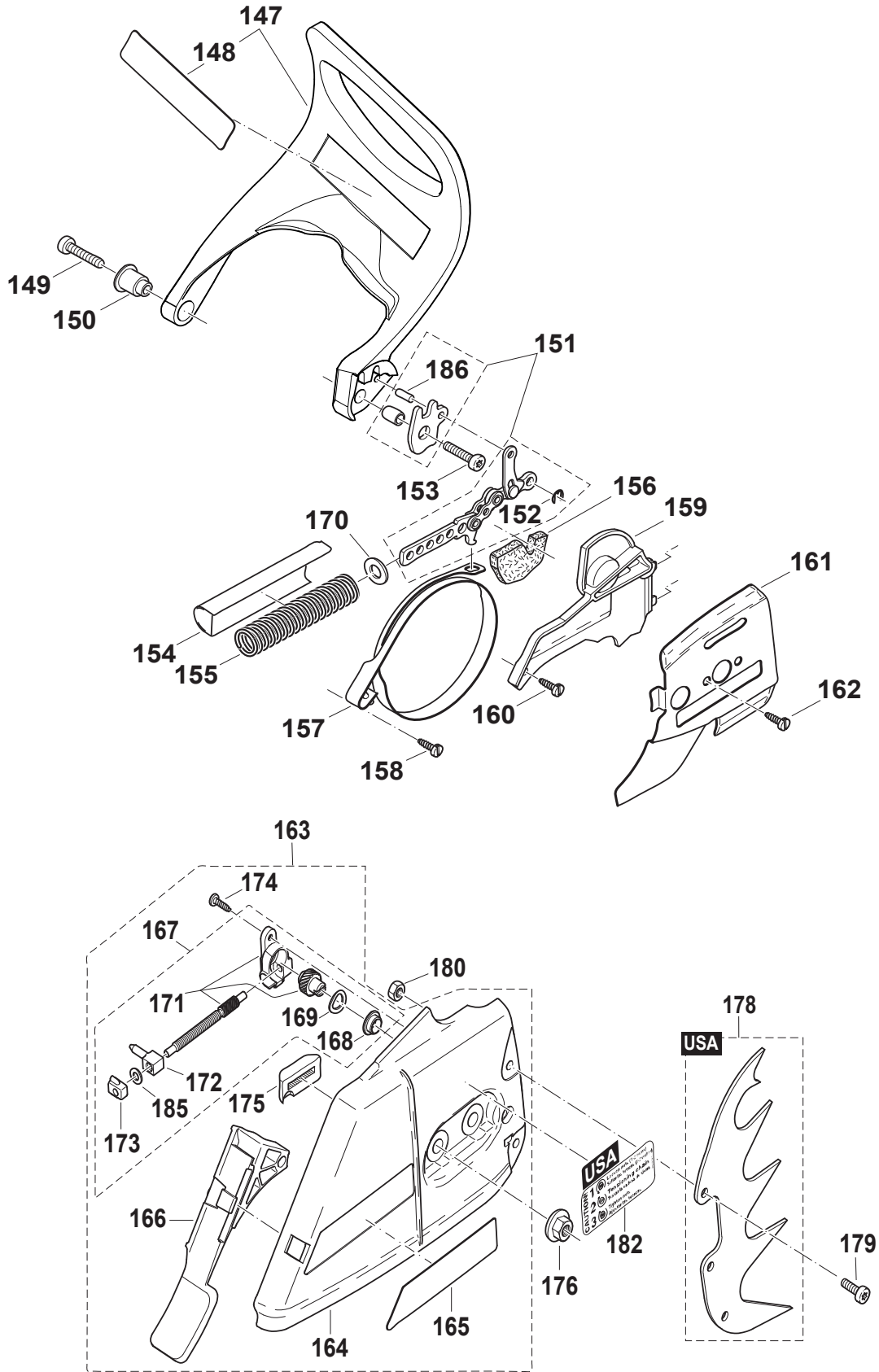

Products with multiple versions are listed in subsiding order with the newest version on top not indented.

Section	Fig. No.	Part No.	Description	DCS642120	DCS6421R	PS-6400	PS-6400H	Tech Bulletin	Notes
7	147	038-213-221	HAND GUARD CPL., DCS6401	1	1	1	1		
7	148	810449-4	CAUTION LABEL	1	1	1	1		
7	148	185-114-237	CAUTION LABEL	1	1	1	1		
7	148	980-114-237	LABEL	1		1	1		
7	149	908-405-205	SCREW 5x20	1	1	1	1		
7	150	038-213-160	BUSHING	1	1	1	1		
7	151	957-213-030	BRAKING MECHANISM	1	1	1	1		
7	152	927-304-000	WASHER 4	1	1	1	1		
7	153	908-805-205	SCREW 5x20	1	1	1	1		
7	154	038-213-152	POT, DCS6421	1	1	1	1		
7	154	038-213-150	POT	1		1	1		
7	155	038-213-130	SPRING	1	1	1	1		
7	156	038-213-200	FOAM SPONGE	1	1	1	1		
7	157	038-213-010	BRAKE SPRING	1	1	1	1		
7	158	915-135-100	SCREW BZ3.5x9.5	1	1	1	1		
7	159	038-213-040	PLATE	1	1	1	1		
7	160	251480-5	TAPPING SCREW ST 3.5X9.5, EA4300F	1	1	1	1		
7	160	915-535-100	SCREW BZ3.5x9.5	1	1	1	1		
7	161	038-111-030	GUIDE PLATE	1	1	1	1		
7	162	251480-5	TAPPING SCREW ST 3.5X9.5, EA4300F	1	1	1	1		
7	162	915-535-100	SCREW BZ3.5x9.5	1	1	1	1		
7	163	038-213-641	SPROCKET GUARD CPL., DCS6401	1					BLUE
7	163	038-213-103	SPROCKET GUARD CPL. RED		1	1	1		RED
7	164	038-213-635	SPROCKET GUARD, DCS6401	1					BLUE
7	164	038-213-036	SPROCKET GUARD RED		1	1	1		RED
7	164	038-213-035	SPROCKET GUARD RED			1	1		
7	165	980-116-004	LABEL, PS-6400			1	1		
7	165	980-114-593	LABEL			1	1		
7	166	038-213-190	CHIP GUIDE	1	1	1	1		
7	167	957-213-023	CHAIN TENSIONER, DCS6401	1	1	1	1		
7	168	038-213-080	BUSHING	1	1	1	1		
7	169	038-213-230	SPRING WASHER	2	2	2	2		
7	170	028-213-012	WASHER, DCS6421	1	1	1	1		
7	170	028-213-011	WASHER, DCS6421	1		1	1		
7	170	028-213-010	WASHER 12x9	1		1	1		

Products with multiple versions are listed in subsiding order with the newest version on top not indented.

Section	Fig. No.	Part No.	Description	DCS642120	DCS6421R	PS-6400	PS-6400H	Tech Bulletin	Notes
7	171	957-213-040	TENSIONING SCREW, DCS6401	1	1	1	1		
7	172	038-213-091	SQUARE NUT, DCS6401	1	1	1	1		
7	173	038-213-070	TENSIONING SCREW BEARING	1	1	1	1		
7	174	251480-5	TAPPING SCREW ST 3.5X9.5, EA4300F	1	1	1	1		
7	174	915-535-100	SCREW BZ3.5x9.5	1	1	1	1		
7	175	024-213-240	CHAIN GUIDE	1	1	1	1		
7	176	923-208-004	HEX. NUT M8	2	2	2	2		
7	178	038-250-232	SPIKE BAR	1	1	1	1		
7	178	038-250-212	SPIKE BAR			1	1		
7	178	038-250-211	SPIKE BAR, DCS6401			1	1		
7	179	908-005-125	SCREW M5x12	2	2	2	2		
7	180	920-405-000	HEX. NUT M5	2	2	2	2		
7	182	980-114-925	CAUTION LABEL, DCS6401	1					
7	185	924-104-300	WASHER, DCS6401	1	1	1	1		
7	186	935-940-100	CYLINDRAL PIN, DCS-6401	1	1	1	1		

2012 =>

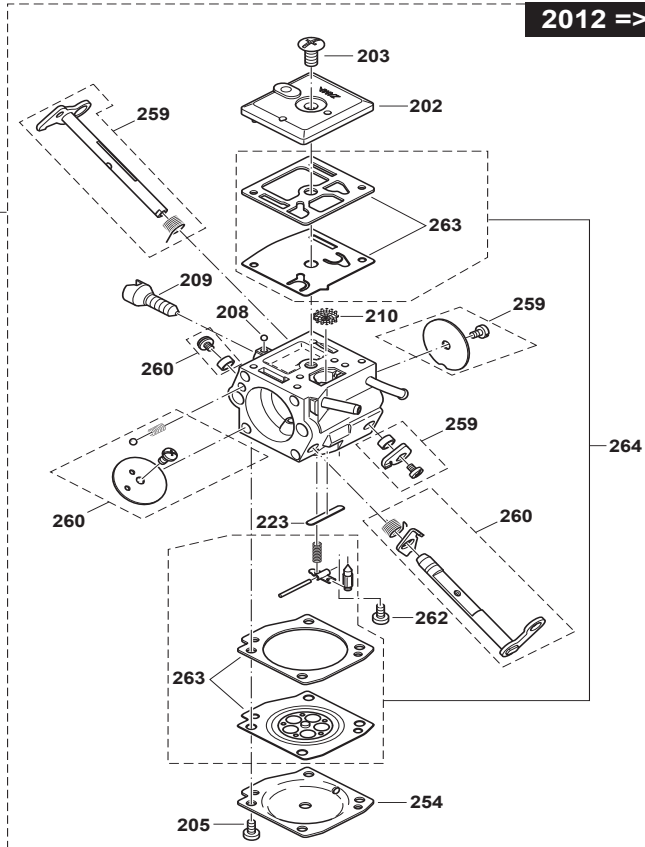
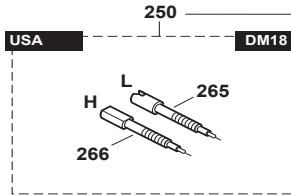

=> 2011

Previous models

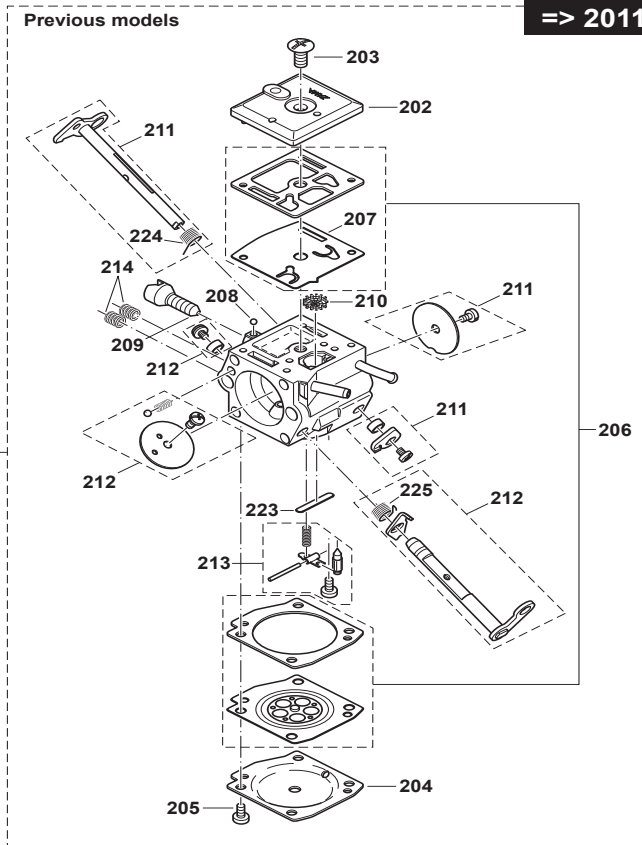
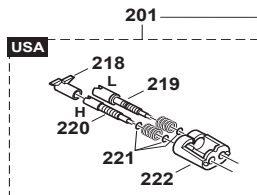

DCS6421, DCS6421R PS-6400



Carburetor

Products with multiple versions are listed in subsiding order with the newest version on top not indented.

Section	Fig. No.	Part No.	Description					Tech Bulletin	Notes
				DCS642120	DCS6421R	PS-6400	PS-6400H		
8	201	038-153-515	CARBURETOR W/ADJUSTING GUIDE, DCS6421	1	1	1	1		2012-01>
8	201	038-153-500	CARBURETOR CPL., , DCS6421	1		1	1		>2011-12
8	201	038-153-023	CARBURETOR, DCS6401	1		1	1		
8	202	038-153-030	PUMP COVER	1	1	1	1		
8	203	038-153-360	SCREW	1	1	1	1		
8	204	038-153-040	DIAPHRAGM COVER	1	1	1	1		>2011-12
8	205	001-153-020	SCREW	4	4	4	4		
8	206	038-153-410	DIAPHRAGM/GASKETS SET, DCS6401	1	1	1	1		>2011-12
8	207	038-153-070	PUMP DIAPHRAGM, TEFLON	1	1	1	1		>2011-12 Standard Equipment
8	207	038-153-370	PUMP DIAPHRAGM, RUBBER	1	1	1	1		>2011-12 Accessory Item
8	208	038-153-210	LOCKING BALL	1	1	1	1		
8	209	038-153-220	IDLE STOP SCREW (S)	1	1	1	1		
8	210	036-153-040	SCREEN, DCS34	1	1	1	1		
8	211	957-153-061	THROTTLE SHAFT KIT, DCS6401	1	1	1	1		>2011-12
8	212	957-153-051	CHOKE SHAFT KIT, DCS6401	1	1	1	1		>2011-12
8	213	957-153-100	CONTROL PARTS, DCS6401	1	1	1	1		>2011-12
8	214	038-153-260	SPRING	2	2	2	2		>2011-12
8	218	038-153-310	LIMITER CAP			1	1		>2011-12
8	219	038-153-290	IDLE ADJUSTM. SCREW-L			1	1		>2011-12
8	220	038-153-300	MAIN ADJUSTM. SCREW-H			1	1		>2011-12
8	221	038-153-250	WASHER			3	3		>2011-12
8	222	038-153-320	ADJUSTING GUIDE			1	1		>2011-12
8	223	038-153-350	WELCH PLUG, DCS6421	1	1	1	1		>2011-12
8	250	038-153-515	CARBURETOR W/ADJUSTING GUIDE, DCS6421	1	1	1	1		2012-01>
8	254	038-153-540	DIAPHRAGM COVER ASSY, DCS6421	1	1	1	1		2012-01>
8	259	038-153-570	THROTTLE SHAFT KIT, DCS6421	1	1	1	1		2012-01>
8	260	038-153-580	CHOKE SHAFT KIT, DCS6421	1	1	1	1		2012-01>
8	262	028-153-200	SCREW, DCS6421	1	1	1	1		2012-01>
8	263	038-153-550	SET DIAPHRAGMS / GASKETS, DCS6421	1	1	1	1		2012-01>
8	264	038-153-560	REBUILD KIT, DCS6421	1	1	1	1		2012-01>
8	265	038-153-232	IDLE ADJUSTMENT SCREW, DCS6421	1	1	1	1		2012-01>
8	266	038-153-301	MAIN ADJUSTMENT SCREW, DCS6421	1	1	1	1		2012-01>

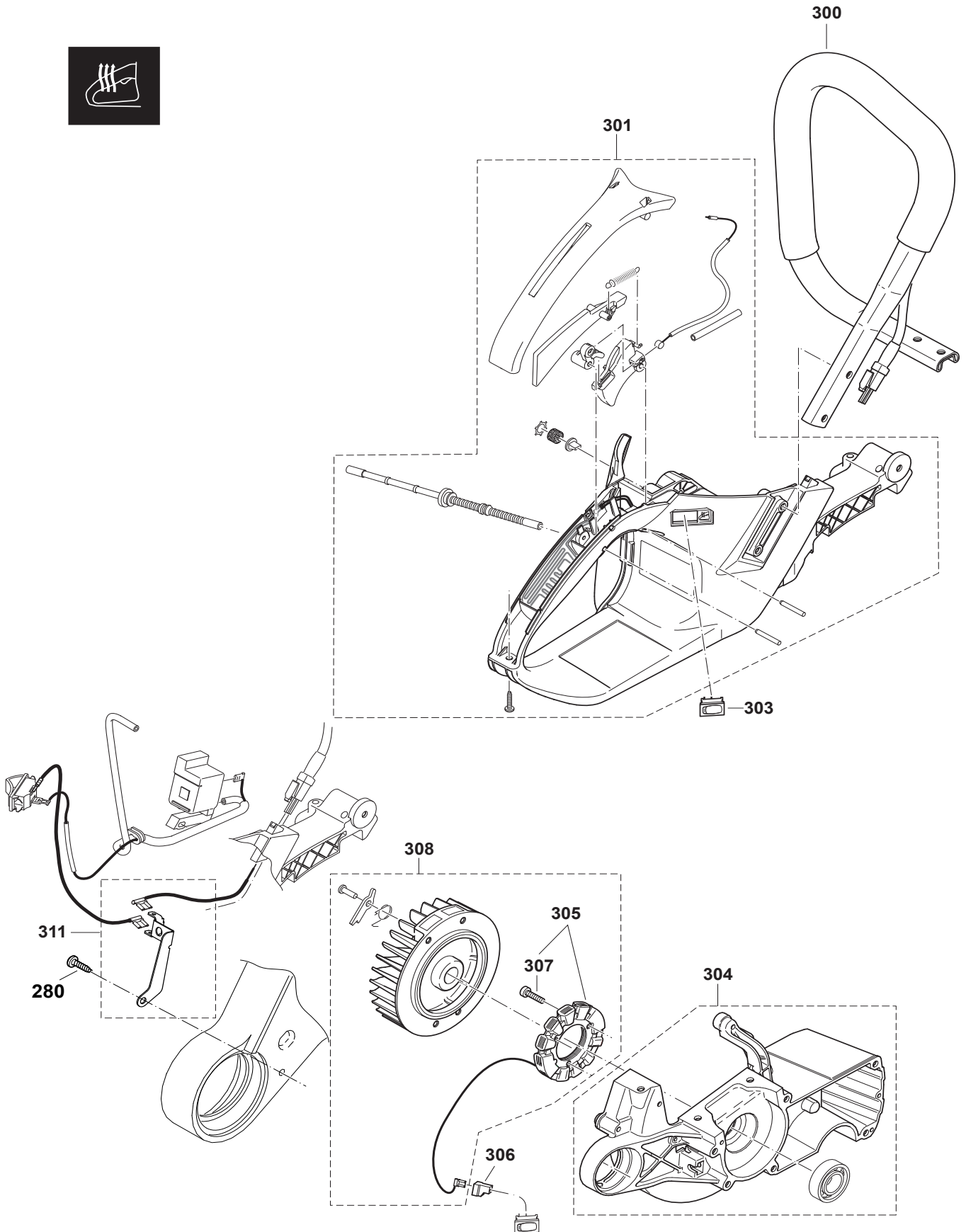

Products with multiple versions are listed in subsiding order with the newest version on top not indented.

Section	Fig. No.	Part No.	Description	DCS642120	DCS6421R	PS-6400	PS-6400H	Tech Bulletin	Notes
9	280	251480-5	TAPPING SCREW ST 3.5X9.5, EA4300F	1	1	1	1		
9	280	915-535-100	SCREW BZ3.5x9.5	1	1	1	1		
9	300	038-310-031	TUBULAR HANDLE ASSY., PS-6400H				1		ONLY FOR HEATED HANDLE MODELS
9	301	038-114-090	TANK CPL. RED, PS-6400H				1		ONLY FOR HEATED HANDLE MODELS
9	303	975-001-250	SWITCH, PS-6400H				1		ONLY FOR HEATED HANDLE MODELS
9	304	038-111-180	CRANKC. MAG. SIDE RED, PS-6400H				1		ONLY FOR HEATED HANDLE MODELS
9	305	957-148-020	GENERATOR COIL, PS-6400H				1		ONLY FOR HEATED HANDLE MODELS
9	306	038-146-030	INSULATING CAP, PS-6400H				1		ONLY FOR HEATED HANDLE MODELS
9	307	913-340-205	SCREW M4X20				3		ONLY FOR HEATED HANDLE MODELS
9	308	957-148-002	FLYWHEEL ASSY, PS-6400H				1		ONLY FOR HEATED HANDLE MODELS
9	310	038-143-041	IGNITION COIL RED, DCS6401H	1	1	1	1		
9	311	957-311-590	EARTH CABLE, DCS6421	1	1	1	1		

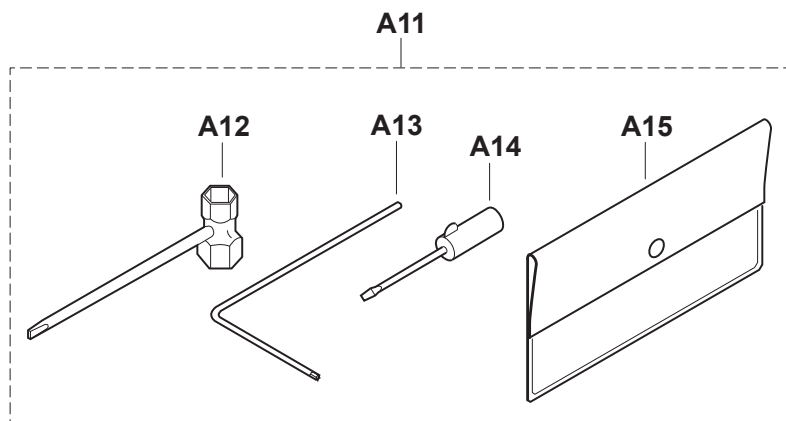
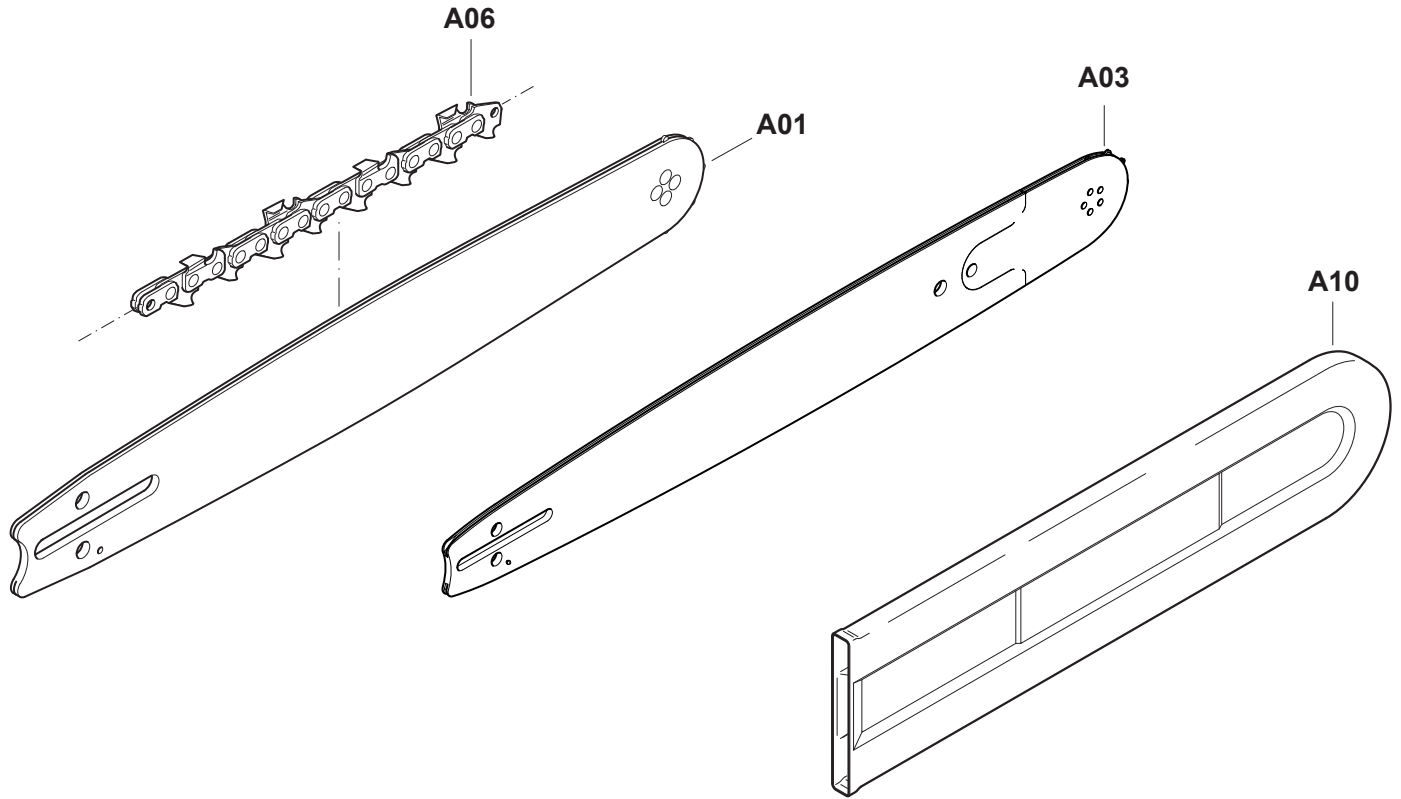

Products with multiple versions are listed in subsiding order with the newest version on top not indented.

Section	Fig. No.	Part No.	Description	DCS642120	DCS6421R	PS-6400	PS-6400H	Tech Bulletin	Notes
10	A01	445-050-665	20" GUIDE BAR .050, 3/8"	1	1				
10	A01	415-050-665	20" GUIDE BAR .050, 3/8"			1	1		
10	A03	431-050-013	20" BAR 3/8 X.050G SPEED TIP			1	1		
10	A03	431-060-013	24" BAR 3/8 X.050G SPEED TIP			1	1		
10	A03	431-070-013	28" BAR 3/8 X.050G SPEED TIP			1	1		
10	A03	431-080-013	32" BAR 3/8 X.050G SPEED TIP			1	1		
10	A06	523-102-072A	20" CHAIN , .050-3/8,DCS6401-20	1	1	1	1		
10	A06	523-100-084	LOOP CHAIN 24" (72VL 84)			1	1		
10	A06	523-100-092	28" CHAIN 3/8x.050-92DL			1	1		
10	A06	523-100-105	32" CHAIN 3/8x.050-105DL			1	1		
10	A10	952-020-650	CHAIN PROTECTION,20"	1	1				
10	A10	952-030-180	CHAIN PROTECTION 32"			1	1		
10	A11	957-004-002	TOOL KIT	1	1	1	1		
10	A12	941-719-133	WRENCH	1	1	1	1		
10	A13	940-827-000	T-27 TORX WRENCH	1	1	1	1		
10	A14	944-340-001	SCREWDRIVER	1	1	1	1		
10	A15	950-004-002	PLASTIC BAG	1	1	1	1		